**Operation
Guide**

Model CX1006/CX1206

DAQSTATION CX1000



Contents

Introduction to Control Functions	4
Control Types	4
PID Control Function	4
Control Suppression Function	5
Tracking Function	6
Control Alarm Function	6
Wiring	7
Overview of Operations	8
Key Operation	8
Switching Operation Modes	8
Switching Displays during Operation Mode	8
Control Operation Display	9
List of Control Setup Items	10
Examples of Control Setup Operation	11
Control Setup Example 1: Single Loop Control	11
Control Setup Example 2: Cascade Control	15
Control Setup Example 3: Loop Control with PV Switching	20
Control Setup Example 4: ON/OFF Control	23
Setting the Display Items on the Control Group Display (Control Group Setting)	26
Displaying the Trend of PV, SP, and OUT Values	27
Switching the Operation Mode	29
Run/Stop Operation	29
Switching between Auto, Manual, and Cascade Control	29
Changing the Target Setpoint	30
Changing the Control Output	30
Switching between Remote and Local Modes	31
Switching between Automatic and Manual for the Analog Retransmission Loop	31
Changing the Analog Retransmission Output	32
Switching between Automatic and Manual for the DIO Operation Monitoring	32
Tuning Operation	33
Displaying the Tuning Display	33
Auto Tuning	33
Manual Tuning	34
Program Control Function (/PG1 and /PG2 Options)	35
Program Control Function Introduction	35
Operation Mode during Program Control	35
Operations on the Program Selection Display (See the figure on the next page)	35
Operations on the Program Control Display (See the figure on the next page)	36
Program Control Setup Operation	38
List of Parameters	44

Thank you for purchasing the CX1000. This operation guide briefly explains the main operations related to the loop control function of the CX1000. For information about all the functions excluding the communication functions, installation and wiring procedures, operating procedures, and handling precautions of the CX1000, see the electronic manual *CX1000 User's Manual (IM 04L31A01-03E)* provided on the accompanying CD-ROM. The following four manuals are provided in addition to this manual and the CX1000 User's Manual. Read them along with this manual.

Electronic Manuals Provided on the Accompanying CD-ROM

Manual Title	Manual No.	Description
CX1000/CX2000 Communication Interface User's Manual	IM 04L31A01-17E	Describes the communication functions of the CX1000 using the Ethernet/serial interface.
DAQSTANDARD for CX User's Manual	IM 04L31A01-61E	Describes the functions and operating procedure of the software "DAQSTANDARD for CX" that comes with the package.

Paper Manuals

Manual Title	Manual No.	Description
CX1000 Installation and Connection Guide	IM 04L31A01-73E	Describes concisely the installation procedures and wiring procedures of the CX1000.
Precautions on the Use of the CX1000/CX2000	IM 04L31A01-72E	Precautions regarding the use of the CX1000/CX2000.

Note

- This manual provides information on the CX1000, style number "S3."
- The contents of this manual are subject to change without prior notice as a result of continuing improvements to the instrument's performance and functions.
- Every effort has been made in the preparation of this manual to ensure the accuracy of its contents. However, should you have any questions or find any errors, please contact your nearest YOKOGAWA dealer as listed on the back cover of this manual.
- Copying or reproducing all or any part of the contents of this manual without the permission of Yokogawa Electric Corporation is strictly prohibited.
- The TCP/IP software of this product and the document concerning the TCP/IP software have been developed/created by YOKOGAWA based on the BSD Networking Software, Release 1 that has been licensed from the Regents of the University of California.

Trademarks

- Microsoft, MS-DOS, Windows, and Windows NT are either registered trademarks or trademarks of Microsoft Corporation in the United States and/or other countries.
- Zip is either a registered trademark or trademark of Iomega Corporation in the United States and/or other countries.
- Adobe and Acrobat are trademarks of Adobe Systems Incorporated.
- Company and product names that appear in this manual are trademarks or registered trademarks of their respective holders.

Revisions

1st Edition	April, 2002
2nd Edition	January, 2003
3rd Edition	June, 2003

Introduction to Control Functions

For further details on each function, see chapter 1, "Explanation of Functions" in the *CX1000 User's Manual (IM 04L31A01-03E)* provided on the accompanying CD-ROM.

Control Types

Control Mode

Three control modes are available.

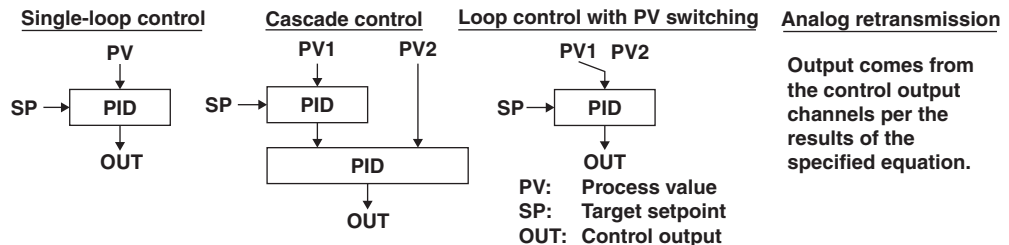

Control Operation Mode

You can specify either of the following control operation modes for each control output terminal block. However, program control operation can be specified only on models with the program control option.

- Fixed-point control (program control OFF): Set the SP locally or use remote input
- Program control operation: Set the SP locally or use program patterns

PID Control Function

Control Computation Types and Control Output Format

You can select from time proportional PID control (voltage pulse/relay output), continuous PID control (current output), or On/Off control (relay output).

Control Direction

You can select the direction in which OUT changes according to the polarity of the deviation between the SP and the PV.

- Reverse action (PV > SP: OUT decreases, PV < SP: control output increases)
- Direct action (PV > SP: OUT increases, PV < SP: control output decreases)

PID Control Mode

You can select the change in the operation when the SP is changed.

- Follow-up: Controlled so that the output reaches the new SP quickly
- Fixed-point: Suppresses sensitive reaction of the output to change to the new SP

PID Control Method

One of the following methods is automatically selected depending on the PID control mode and the control operation mode.

- PV derivative type: Control method in which the control output is kept from changing radically when the SP is changed by a great amount
- Deviation derivative type: Control method in which fast response to follow the SP is emphasized

Control Parameter ("PID Parameter" in the Settings)

You can set up to eight groups of control parameter sets for each loop. Control parameters include SP, PID constant, control output limiter, manual reset value, control direction, and preset output.

PID Parameter Selection Method

You can select the method for switching PID parameters from the following:

- Target setpoint selection: By specifying the SP number.
- Zone PID selection: By dividing the measurement span in to multiple zones and determining in which zone the PV resides.
- Segment PID selection: Using the program pattern segment when in program control.

Tuning

There are two methods: auto tuning of PID constants using the limit cycle method, and manual tuning that allows PID parameters to be set individually during operation.

Control Suppression Function

Anti-Reset Windup (Over-Integration Prevention)

Overshoot may occur if the deviation between the SP and PV continues for an extended time and the control output reaches the output high-limit through the integration process. To prevent this from happening, the anti-reset windup function is used to pause the integration process when the manipulated output reaches the high limit of the output limiter.

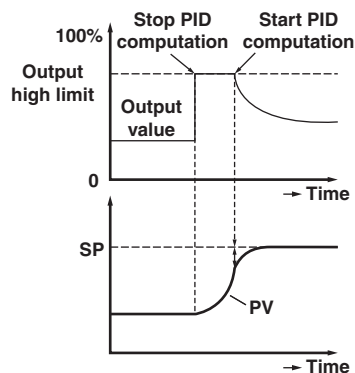

Overshoot Suppression Function (“Control Output Suppression” in the Settings)

The deviation is monitored to detect the danger of overshooting and automatically changes the SP to a slightly lower tentative value referred to as the “auxiliary target setpoint” and continues control. Then, when the process value enters a range in which overshooting is no longer a danger, the auxiliary target setpoint is gradually returned to the original SP.

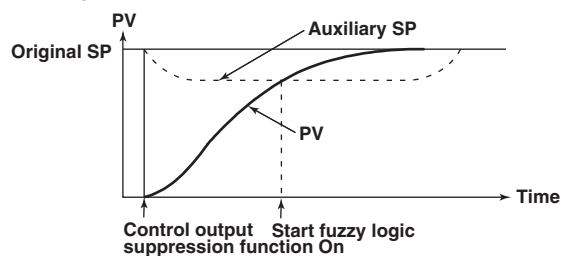

Control Output Limiter

You can set high and low limits of the control output range (“output high-limit/low-limit” in the settings) regardless of the operation mode.

Shutdown

This function is used to close the control value fully (set the output to 0) exceeding the dead band of the control valve positioner.

Output Velocity Limiter

This function is used to prevent radical changes in the control output to protect the control element and object of control.

Preset Output

This function sets the control output to the preset value when the operation is stopped.

SP Ramp-Down-Rate/SP Ramp-Up-Rate

This function is used to decrease or increase the setpoint at a constant rate of change (as opposed to a rapid change) when the SP is changed.

Target Setpoint Limit

This function is used to limit the range of values that the SP can change.

Tracking Function

You can set the following two tracking functions to suppress a radical change in the output.

SP tracking: When switching from remote to local operation mode, the output is tracked to the remote SP immediately before the SP switching.

PV tracking: The SP is matched to the PV at that point and then returned to the original value according to the target setpoint ramp-up rate or the target setpoint ramp-down rate.

Control Alarm Function

You can set up to four alarms for each loop. The following alarm types can be specified. PV upper-limit alarm, PV lower-limit alarm, deviation high limit alarm, deviation low limit alarm, deviation high/low limit alarm, deviation high and low limits alarm, SP high limit alarm, SP low limit alarm, output high limit alarm, and output low limit alarm.

Wiring

Input/Output terminals are arranged on the rear panel of the CX1000 as shown in the figure below. The figure shows the case when option terminals are specified on the model with 6 internal control loops and 20 measurement channels (CX2620). For the wiring procedure of the control/measurement input/output, see chapter 2, "Installation and Wiring" in the *CX1000 User's Manual (IM 04L31A01-03E)* or the *CX1000 Installation and Connection Guide (IM 04L31A01-73E)*. For a description on the connection of communication interfaces such as the serial or Ethernet interface, see the *CX1000/CX2000 Communication Interface User's Manual (IM 04L31A01-17E)*.

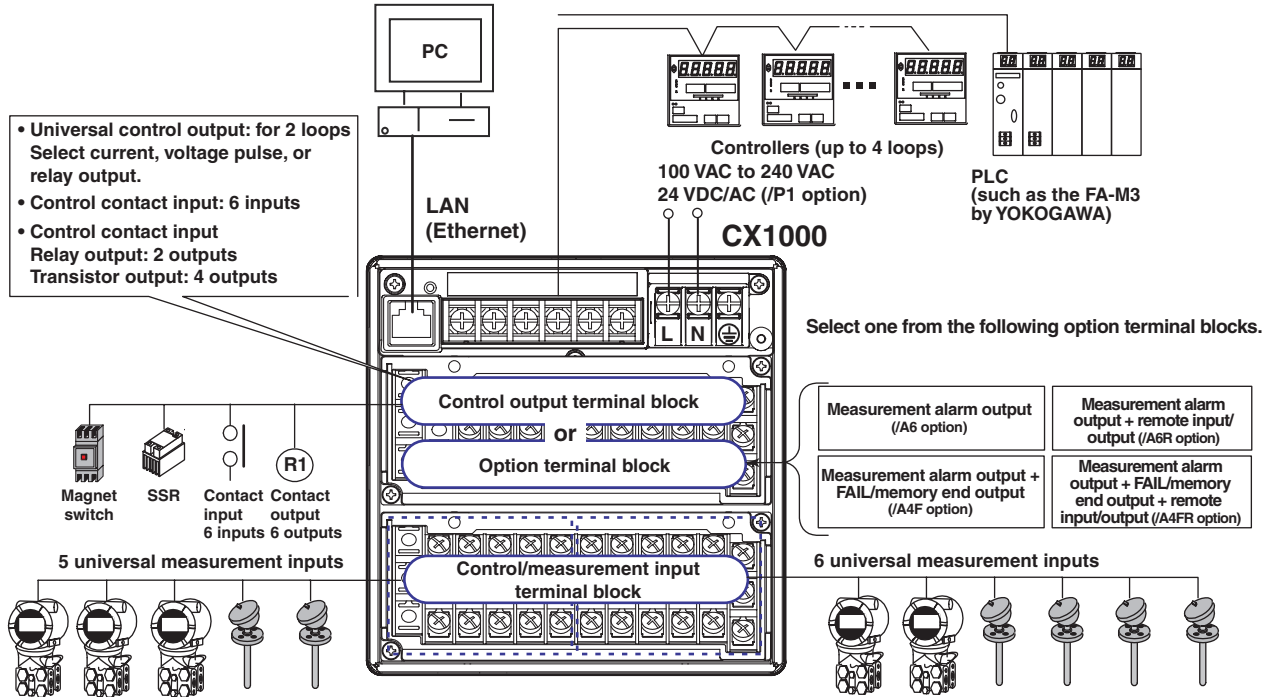

Control Terminal Arrangement of the Control/Measurement Input Terminal Block (Conceptual Diagram)

The following figure denotes the three terminals (/b, +/A, -/B) of a single column of control input terminals using a single cell.

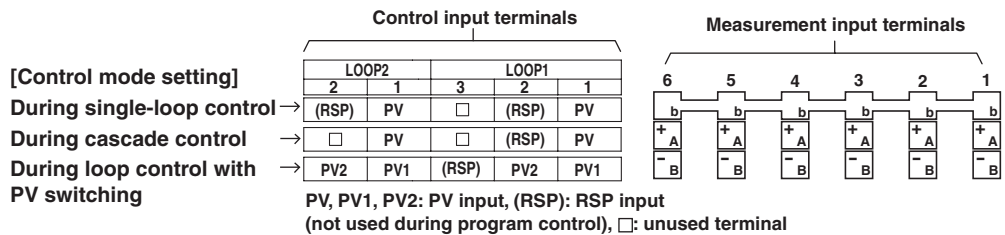

Terminal Arrangement of the Control Output Terminal Block

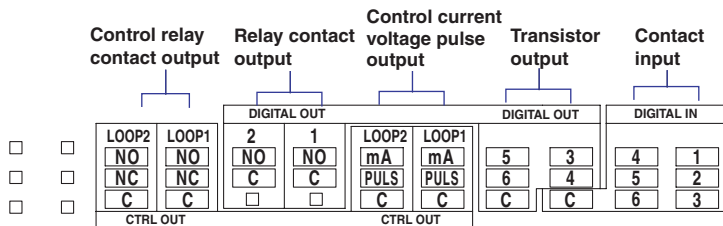

Overview of Operations

Key Operation

For details on the key operation, see chapter 3, "Names of Parts, Display Modes, and Common Operations" in the *CX1000 User's Manual (IM 04L31A01-03E)*.

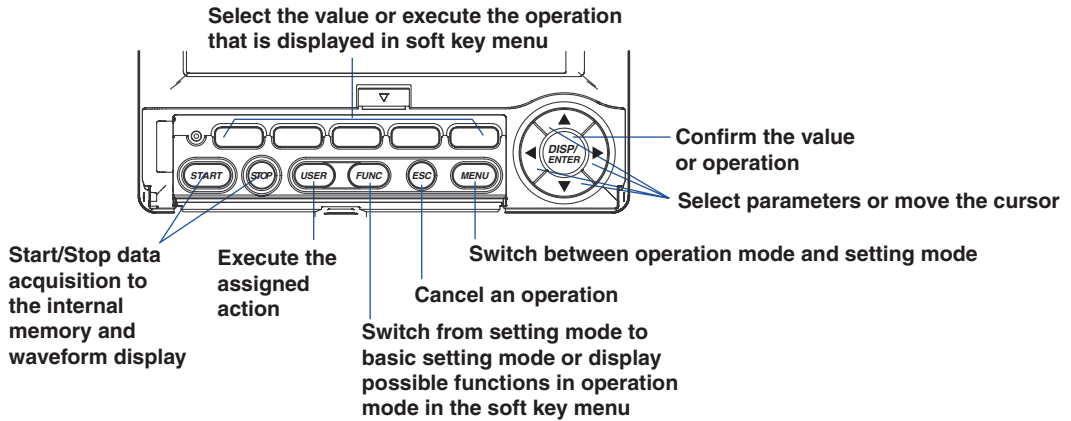

Switching Operation Modes

There are four operation modes: operation mode, control setting mode, common and measurement setting mode, and basic setting mode.

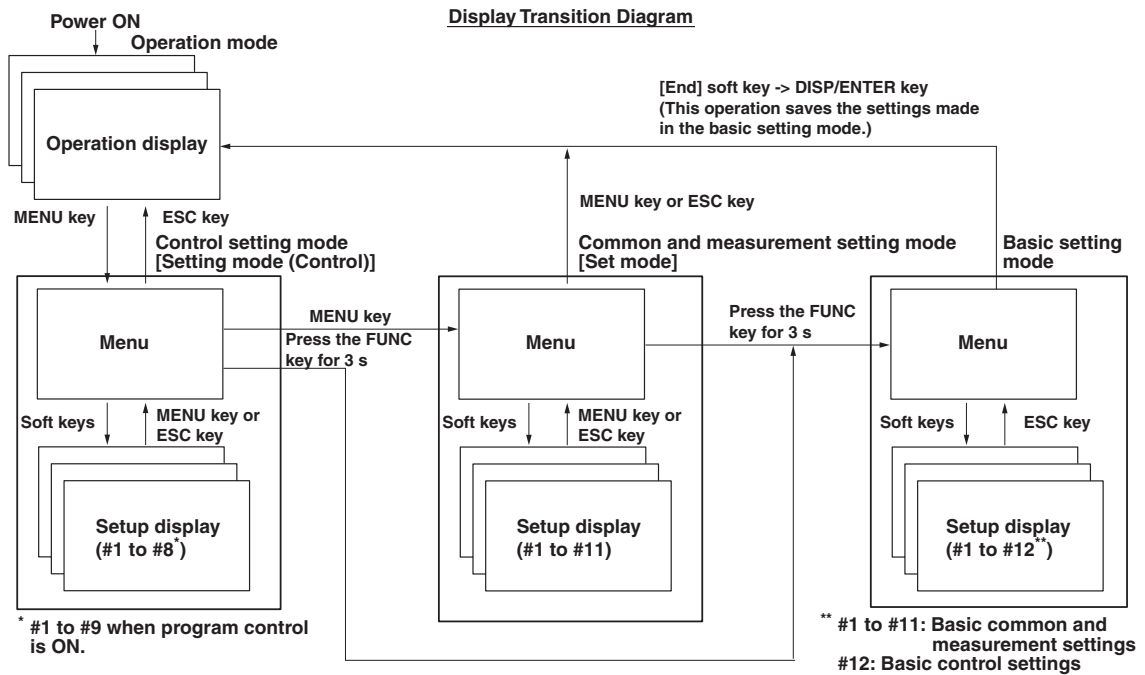

Switching Displays during Operation Mode

You can change the operation display according to your needs by carrying out the following procedures.

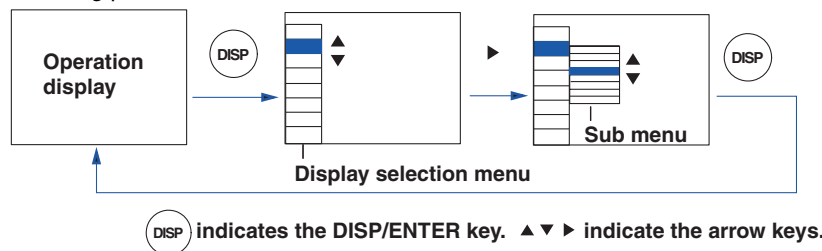

Control Operation Display

In operation mode, the following control operation displays can be selected.

- Control group display
This display is used to monitor the control status of multiple loops simultaneously including external loops. You can select from three display styles as shown in the display example in the figure below. If you include the measurement channels for the measurement function in the group, you can also monitor the measured values on the measurement channels at the same time on this display.
- Tuning display
This display is used to optimize (tune) the control parameters such as PID constants.
- Overview display
This display is used to monitor the alarm status of all control loops.
- DI/DO status display
Displays the ON/OFF status of the current contact input (DI) and contact output (DO).
- Control action summary display
Displays a log of control actions such as operation run/stop and auto/manual operation switching.
- Internal switch status display
Displays the ON/OFF status of the internal switch.

On models with the program control function option, the following additional displays are available: 1) the program operation status display, which can show the pattern and current PV accumulated on the screen during program operation and 2) the program event summary display, which shows a log of time events and PV events that occurred during program operation.

Displays common with the measurement function include: 1) the alarm summary display, which shows a log of alarm occurrence status and 2) the memory summary display, which shows the file information of the internal memory.

In addition, on the trend display of the control function, the PV, SP, OUT can be assigned to virtual channels (control channels), and the trend of control status can be displayed like the trend waveforms of measurement channels on the trend display of the measurement function.

Display Examples

• Control group display

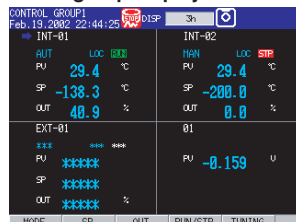

Controller style

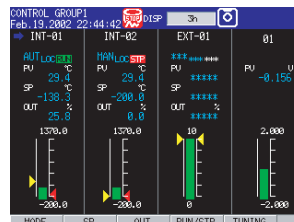

Faceplate style

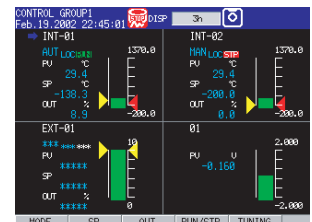

Hybrid style

• Tuning display

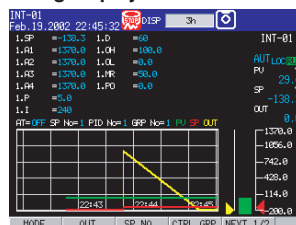

• Overview display



• DI/DO status display

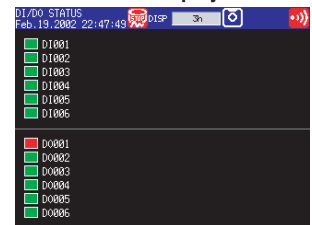

• Control operation summary display

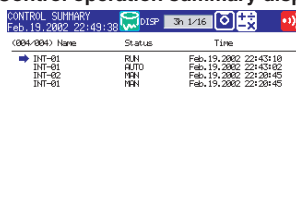

• Internal switch status display

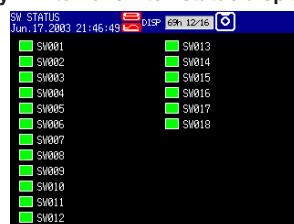

• Trend display

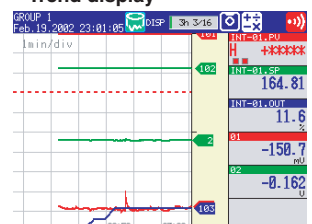

List of Control Setup Items

Basic Control Setup Items in Basic Setting Mode

- #1 Control action
PID number, control period, zone PID, restart mode, restart mode (program) (only on models with the control option), initial PID, auto tuning, control mode, method (only during loop control with PV switching), program control ON/OFF (only on models with the program control option), and PID control mode.
- #2 Input setting
Burnout and RJC.
- #3 DI/DO/SW-registration
Contact input registration
- #4 AUX
Remote setting, alarm mode, SP number selection source, PV/SP math, and CLOG error.
- #5 Output processing
Control output, cycle time, and analog-output type
- #6 Relay
FAIL ON/OFF, self diagnosis ON/OFF, and relay action/behavior (energize/de-energize, hold/nonhold)
- #7 Tuning setting
Tuning item selection
- #8 External loop setting (For details on the settings, see the *CX1000/CX2000 Communication Interface User's Manual (IM 04L31A01-17E)*.)

Setup Items in the Control Setting Mode

- #1 Control input range
Input type, mode, type, range, span, scale, unit, square root, low-cut, bias, filter, and ratio.
- #2 Control alarm
Type, standby, relay output ON/OFF, and alarm value
- #3 Operation-related parameters/Zone PID
Suppressing function, ramp-rate-time unit, SP ramp-down-rate/SP ramp-up-rate, tag, tag comment, reference point (when zone PID is selected), switching hysteresis (when zone PID is selected), and reference deviation (when zone PID is selected).
- #4 PID parameters
SP, PID constant, output limit, shutdown ON/OFF, manual reset, relay hysteresis (only during ON/OFF control), reverse/direct, and preset output.
- #5 Control group setting
Group name, kind (internal loop/external loop/measurement channel), and number.
- #6 Ten-segment linearizer I/O
Input type, mode, and biasing or approximation input/output values.
- #7 Program control (only when program control is ON)
 - #1 Program parameter setting
Pattern initial setting, wait action setting, program start setting, program pattern setting, event setting, and repeat action setting.
 - #2 Event output setting
Event kind, relay output ON/OFF, number, and program pattern end signal relay output ON/OFF.
 - #3 AUX (Auto message, Display position)
Auto message for program Run/Reset and Program display position.
- #8 Detailed setting (“#7” when program control is OFF)
 - #1 Control function
SP tracking, PV tracking, SP limiter, output velocity limiter, and anti-reset windup auto/manual.
 - #2 Hysteresis (Alarm and PV event)
Alarm hysteresis and PV event hysteresis

Examples of Control Setup Operation

Control Setup Example 1: Single Loop Control

Object of Control and Description

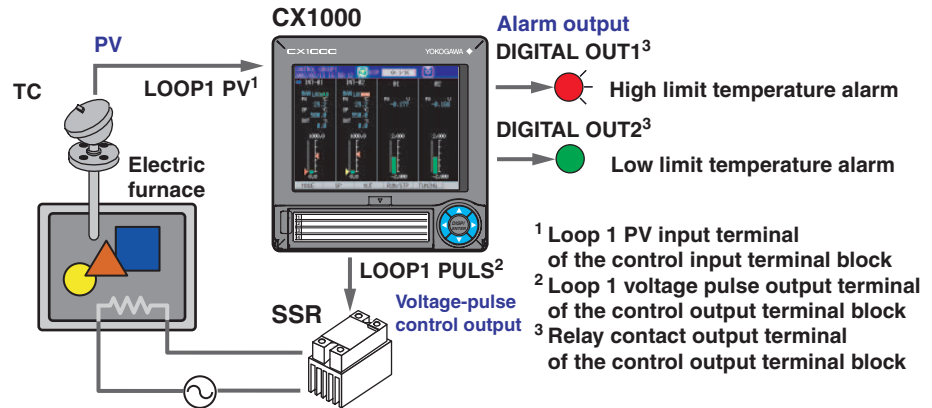

- Loop number: 1
- PID constant: P = 5%, I = 240 s, D = 60 s
- Control direction: Reverse
- Input type: TC K type
- Measurement span: 0 to 1200°C
- Output type: Voltage pulse (cycle time: 3 s)
- Temperature setpoint: 700°C
- Alarm output: PV high-limit alarm (high limit: 800°C), PV low-limit alarm (low limit: 600°C)

Basic Control Settings

1. From the operation display, open the basic control setting menu according to the following procedure.

Press the **MENU key** (to switch to Set mode), then hold down the **FUNC key** for 3 s (to switch to basic setting mode). Press the **Next 1/4 soft key**, followed by the **Next 2/4 soft key**, and then the **#10 soft key** (to select Control).

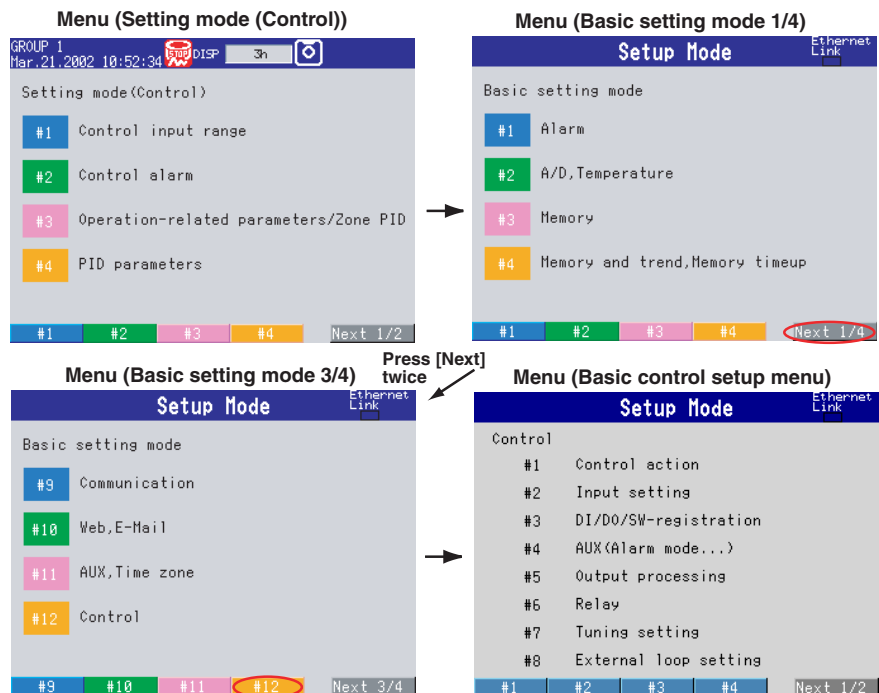

Examples of Control Setup Operation

2. Press the **#1 soft key** (Control action, Input setting).
3. Press the **arrow keys** to move the cursor (blue) to the setup item box, press the **soft key** of each value according to the following figure, and then press the **DISP/ENTER key**.

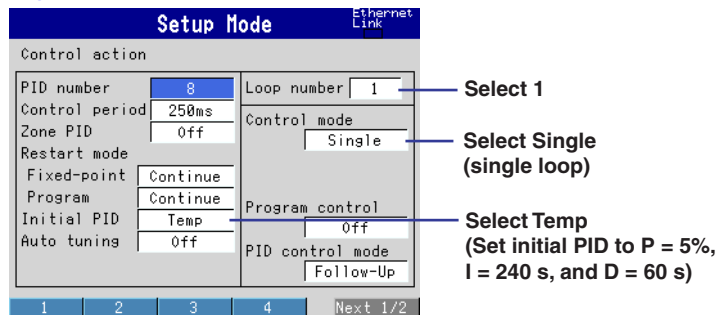

4. Press the **ESC key** to return to the basic control setting menu.
5. Press the **Next 1/2 soft key**, and then the **#5 soft key** (Output processing).
6. Press the **arrow keys** to move the cursor (blue) to the setup item box, press the **soft key** of each value according to the following figure, and then press the **DISP/ENTER key**.

To set Cycle time, press the **Input soft key** to open a numeric entry pop-up window. Enter the value using the **arrow keys** and the **DISP/ENTER key**.

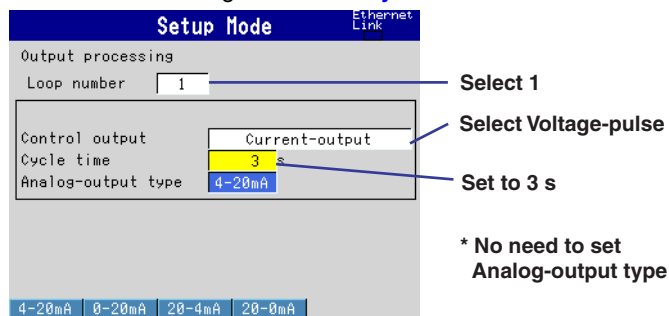

7. Press the **DISP/ENTER key** to confirm the settings.
8. Press the **ESC key** twice to return to the menu display (basic setting mode 3/4).
9. Press the **Next 3/4 soft key** to show the menu display (basic setting mode 4/4).
10. Press the **End soft key**.

A confirmation window shown below opens.



11. Press the **DISP/ENTER key** to confirm the settings.

Setting the Control Input Range in Setting Mode

1. From the operation display, click the **MENU** key to display the control setting menu shown below.

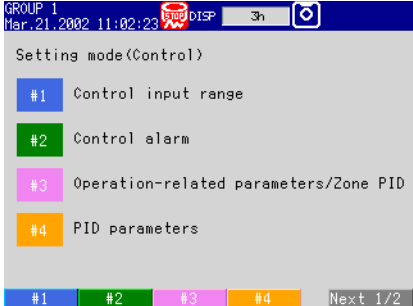

- 2. Press the **#1** soft key (Control input range).
- 3. Press the **arrow keys** to move the cursor (blue) to the setup item box, press the **soft key** of each value, and press the **DISP/ENTER** key.
To set the measurement span (span lower/upper-limit), press the Input soft key and use the numeric entry pop-up window that opens.

4. Press the **DISP/ENTER** key.
A confirmation window shown below opens.

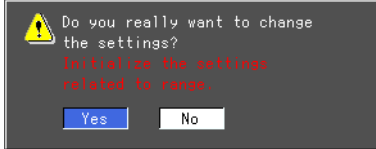

5. Press the **DISP/ENTER** key to confirm the settings.

Setting Control Alarms in Setting Mode

1. From the operation display, click the **MENU key** to display the control setting menu.
2. Press the **#2 soft key** (Control alarm).
3. Press the **arrow keys** to move the cursor (blue) to the setup item box, press the **soft key** of each value according to the following figure.

The numeric value of the alarm is entered using the pop-up window that appears by pressing the Input soft key.

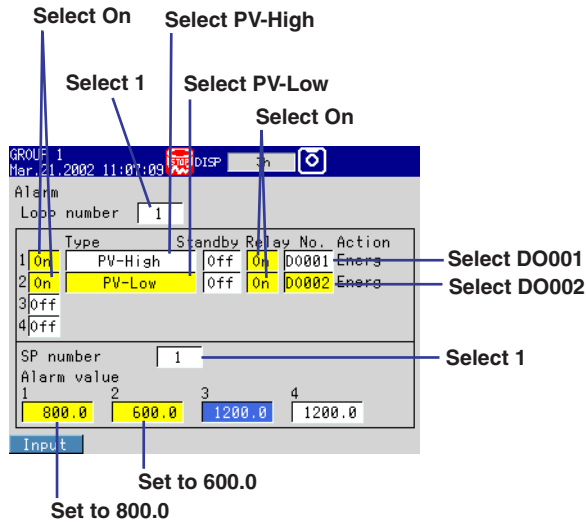

4. Press the **DISP/ENTER key** to confirm the settings.

Setting PID Parameters in Setting Mode

1. From the operation display, click the **MENU key** to display the control setting menu.
2. Press the **#4 soft key** (PID parameters).
3. Press the **arrow keys** to move the cursor (blue) to the setup item box, press the **soft key** of each value according to the following figure.

The numerical values such as the SP are entered using the pop-up window that appears by pressing the Input soft key.

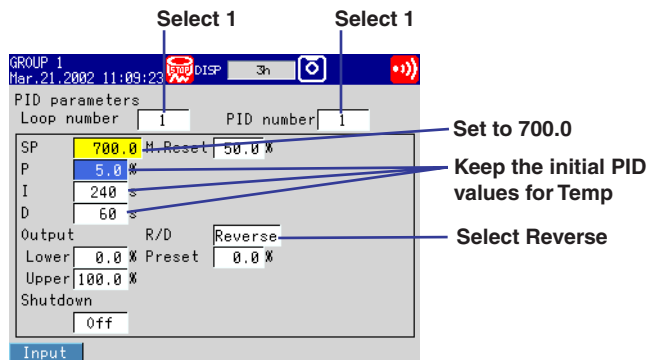

4. Press the **DISP/ENTER key** to confirm the settings.

Control Setup Example 2: Cascade Control

Object of Control and Description

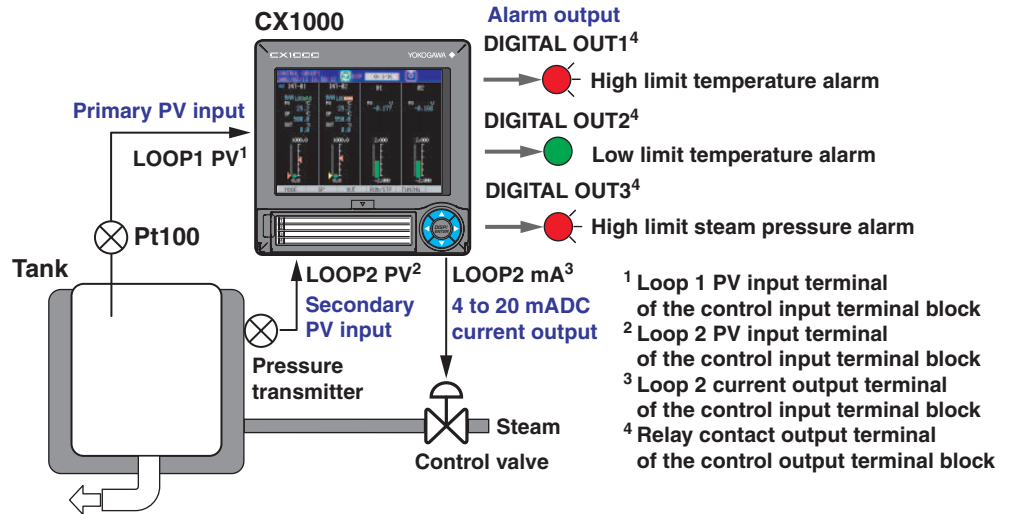

Primary loop of cascade control

- Loop number: 1
- PID constant: P = 20%, I = 300 s, D = 60 s
- Control direction: Reverse
- Input type: RTD Pt100
- Measurement span: 0 to 100°C
- Temperature setpoint: 80°C
- Alarm output: PV high-limit alarm (high limit: 90°C), PV low-limit alarm (low limit: 70°C)

Secondary loop of cascade control

- Loop number: 2
- PID constant: P = 120%, I = 20 s, D = 0 s
- Control direction: Reverse
- Input type: 1-5 V
- Measurement span: 0 to 1.00 MPa
- Output type: Current output (4-20 mA)
- Alarm output: PV high-limit alarm (high limit: 0.90 MPa)

Basic Control Settings

1. Display the basic control setting menu.

See "Control Setup Example 1" for the steps to show the menu.

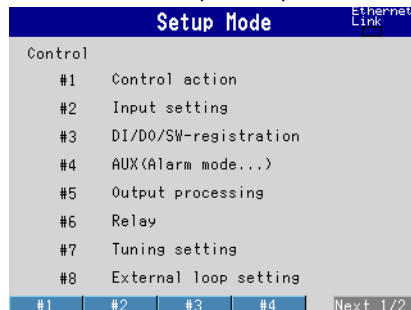

2. Press the **#1 soft key** (Control action, Input setting).
3. Press the **arrow keys** to move the cursor (blue) to the setup item box, press the **soft key** of the value according to the following figure, and press the **DISP/ENTER key**.

Examples of Control Setup Operation

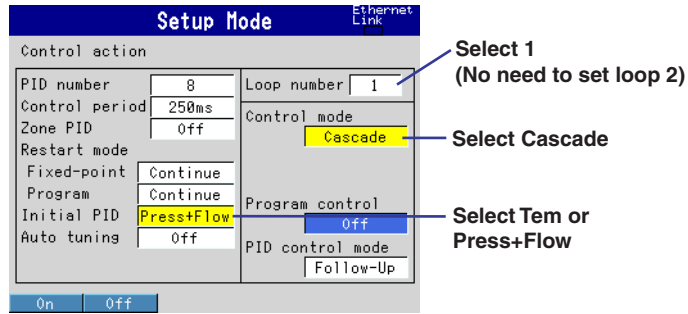

4. Press the **ESC key** to return to the basic control setting menu.
5. Press the **Next 1/2 soft key**, and then the **#5 soft key** (Output processing).

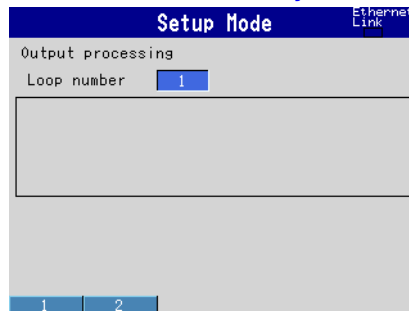

6. Press the **2 soft key**.
There are no control output settings on loop 1 (primary loop of cascade control).
7. Press the **arrow keys** to move the cursor (blue) to the setup item box, press the **soft key** of each value according to the following figure, and press the **DISP/ENTER key**.

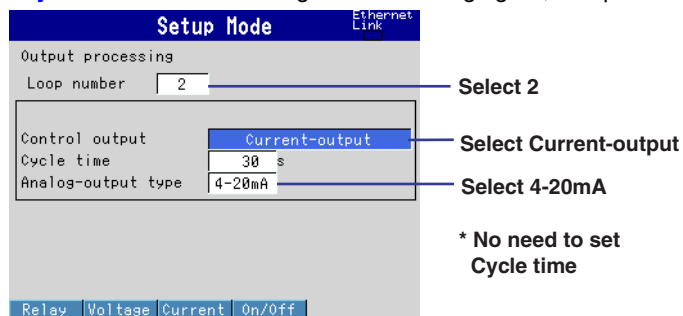

8. Press the **ESC key** twice to return to the menu display (basic setting mode 3/4).
9. Press the **Next 3/4 soft key** to show the menu display (basic setting mode 4/4).
10. Press the **End soft key**.

A confirmation window shown below opens.

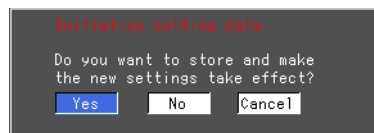

11. Press the **DISP/ENTER key** to confirm the settings.

Setting the Control Input Range in Setting Mode

1. From the operation display, click the **MENU** key to display the control setting menu shown below.

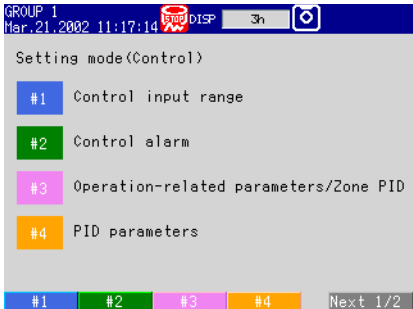

2. Press the **#1** soft key (Control input range).
3. Press the **arrow keys** to move the cursor (blue) to the setup item box, press the **soft key** of each value according to the following figure.
To set the measurement span (span lower/upper-limit), press the Input soft key and use the numeric entry pop-up window that opens.

Setting the Input Range on the Primary Loop of Cascade Control

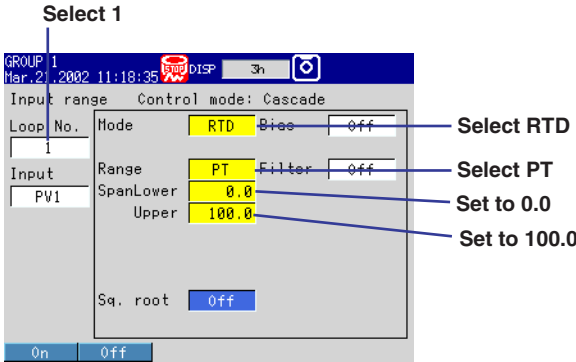

4. Press the **DISP/ENTER** key.
A confirmation window shown below opens.

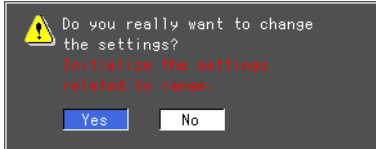

5. Press the **DISP/ENTER** key to confirm the settings.
6. Set the input range of the secondary loop of cascade control in a similar fashion as described in steps 3 to 5 and according to the figure below.
If you do not carry out steps 4 and 5 and change Loop number, the settings are not saved.

Setting the Input Range on the Secondary Loop of Cascade Control

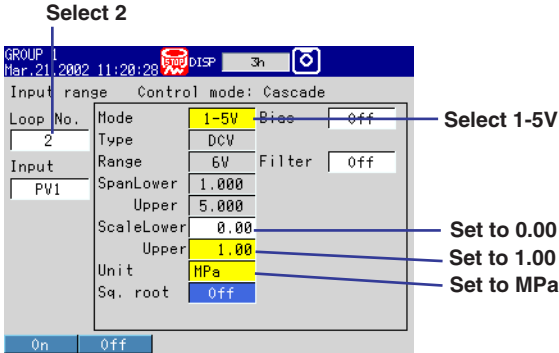

Setting Control Alarms in Setting Mode

1. From the operation display, click the **MENU key** to display the control setting menu.
2. Press the **#2 soft key** (Control alarm).
3. Press the **arrow keys** to move the cursor (blue) to the setup item box, press the **soft key** of each value according to the following figure.

The numeric value of the alarm is entered using the pop-up window that appears by pressing the Input soft key.

Setting Alarms on the Primary Loop of Cascade Control

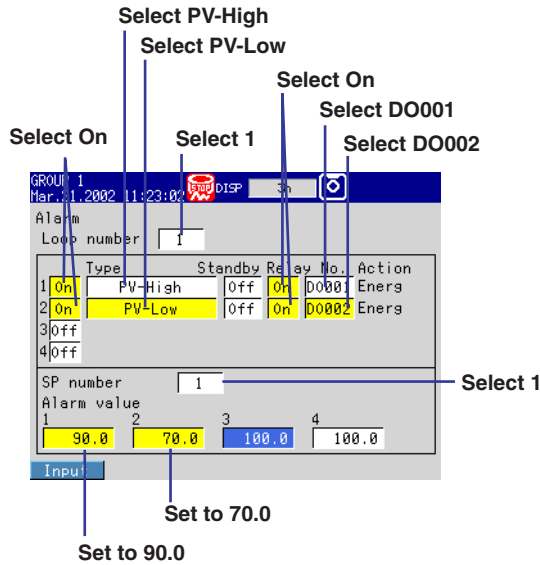

4. Press the **DISP/ENTER key** to confirm the settings.
 5. Set the alarms of the secondary loop of cascade control in a similar fashion as described in steps 3 and 4 and according to the figure.
- If you do not carry out step 4 and change Loop number, the settings are not saved.

Setting Alarms on the Secondary Loop of Cascade Control

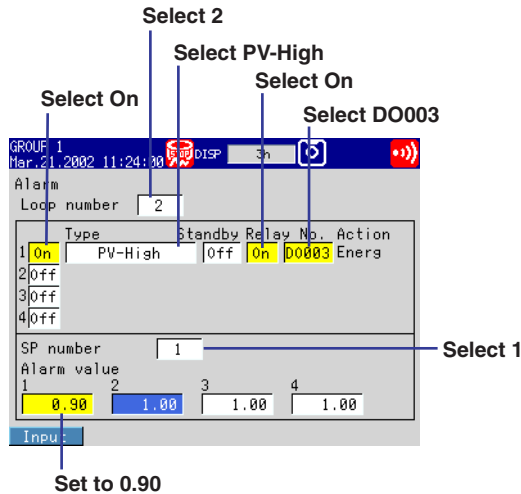

Setting PID Parameters in Setting Mode

- 1. From the operation display, click the **MENU key** to display the control setting menu.
- 2. Press the **#4 soft key** (PID parameters).
- 3. Press the **arrow keys** to move the cursor (blue) to the setup item box, press the **soft key** of each value according to the following figure.

The numerical values such as the SP are entered using the pop-up window that appears by pressing the Input soft key.

Setting PID Parameters on the Primary Loop of Cascade Control

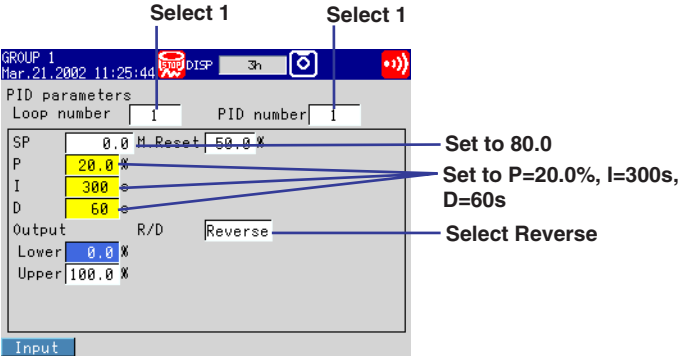

- 4. Press the **DISP/ENTER key** to confirm the settings.
- 5. Set the PID parameters of the secondary loop of cascade control in a similar fashion as described in steps 3 and 4 and according to the figure.

If you do not carry out step 4 and change Loop number, the settings are not saved.

Setting PID Parameters on the Secondary Loop of Cascade Control

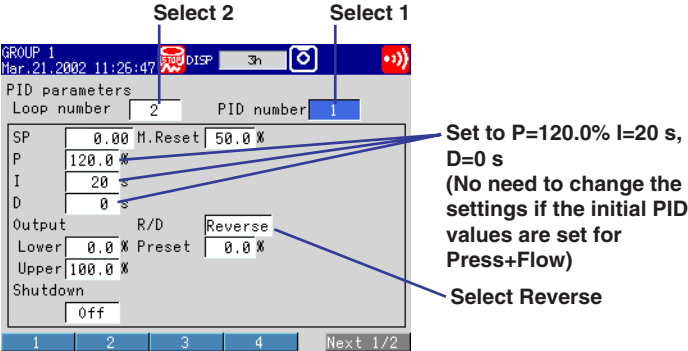

Control Setup Example 3: Loop Control with PV Switching

Object of Control and Description

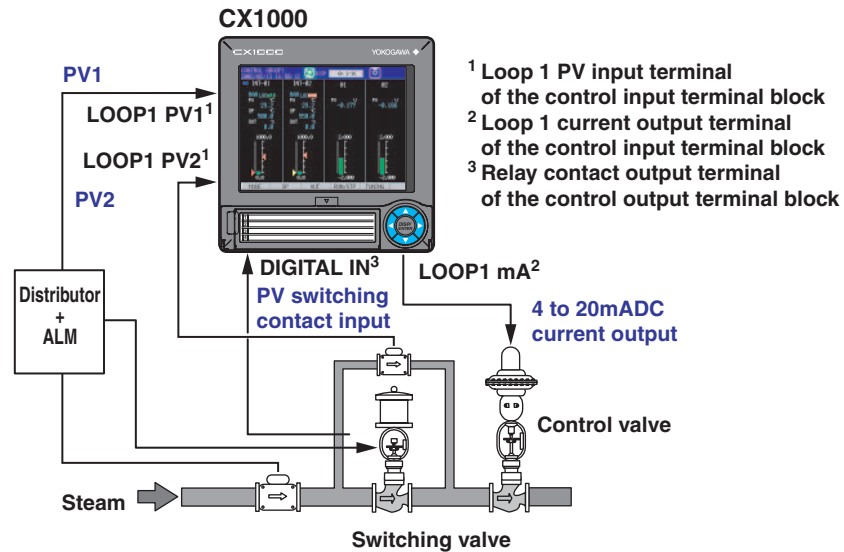

- Loop number: 1
- PID constant: P = 120%, I = 20 s, D = 0 s
- Control direction: Reverse
- Input type: 1-5 V for both measurement input 1 and 2
- Measurement span: PV input 1: 0 to 300 kg/h, PV input 2: 0 to 30 kg/h
- PV range conversion: Lower limit: 0 kg/h, Upper limit: 300 kg/h
- Flow rate setpoint: 100 kg/h
- Input switching condition: Contact input

Basic Control Settings

1. Show the basic control setting menu.
See "Control Setup Example 1" for the steps to show the menu.

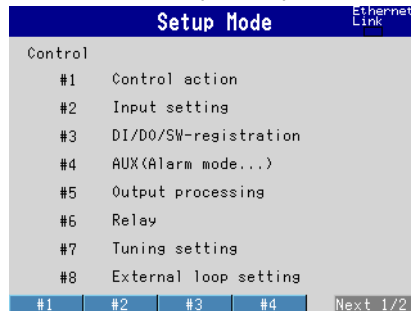

2. Press the **#1 soft key** (Control action, Input setting).
3. Press the **arrow keys** to move the cursor (blue) to the setup item box, press the **soft key** of each value according to the following figure, and press the **DISP/ENTER key**.

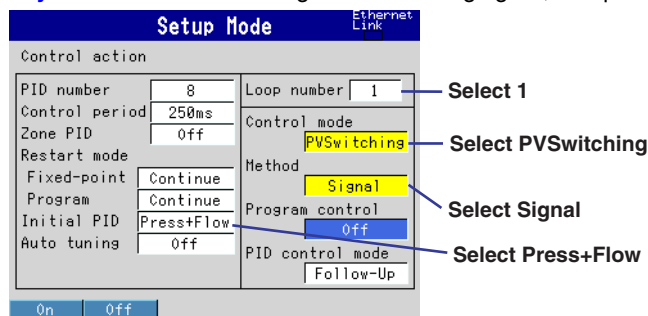

4. Press the **ESC key** to return to the basic control setting menu.
5. Press the **Next 1/2 soft key**, and then the **#5 soft key** (Output processing).
6. Press the **arrow keys** to move the cursor (blue) to the setup item box, press the **soft key** of each value according to the following figure, and press the **DISP/ENTER key**.

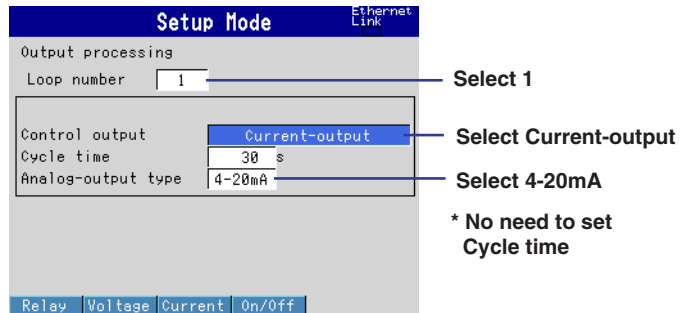

7. Press the **ESC key** twice to return to the menu display (basic setting mode 3/4).
8. Press the **Next 3/4 soft key** to show the menu display (basic setting mode 4/4).
9. Press the **End soft key**.

A confirmation window shown below opens.

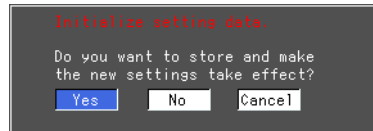

10. Press the **DISP/ENTER key** to confirm the settings.

Setting the Control Input Range in Setting Mode

1. From the operation display, click the **MENU key** to display the control setting menu shown below.

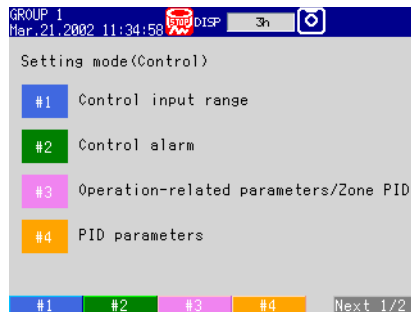

2. Press the **#1 soft key** (Control input range).
3. Press the **arrow keys** to move the cursor (blue) to the Input type box, press the **PV1 soft key**, and set other parameters as shown in the figure below.

Check that 1 is selected

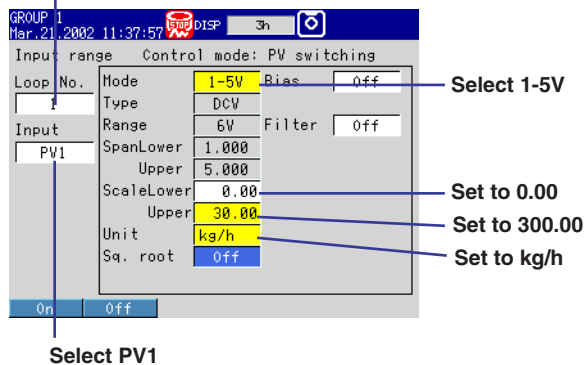

Examples of Control Setup Operation

4. Press the **DISP/ENTER** key.
A confirmation window opens.
5. Press the **DISP/ENTER** key to confirm the settings.
6. Press the **arrow keys** to move the cursor (blue) to the Input type box, press the **PV2** soft key, and set other parameters as shown in the figure below.

Check that 1 is selected

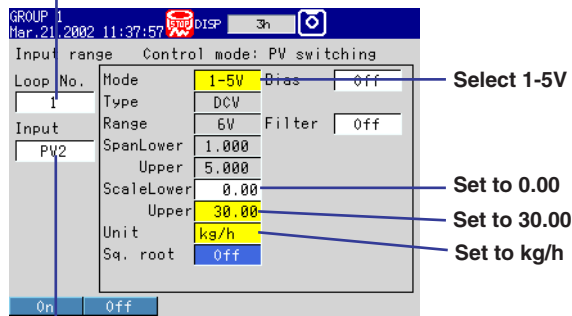

Select PV2

7. Press the **DISP/ENTER** key.
A confirmation window opens.
8. Press the **DISP/ENTER** key to confirm the settings.
9. Press the **arrow keys** to move the cursor (blue) to the Input type box, press the **PVrange** soft key, and set other parameters as shown in the figure below.

Check that 1 is selected

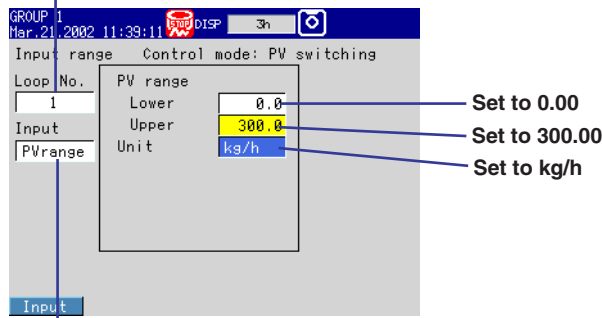

Select PVrange

10. Press the **DISP/ENTER** key.
A confirmation window opens.
11. Press the **DISP/ENTER** key to confirm the settings.

Setting PID Parameters in Setting Mode

1. From the operation display, click the **MENU key** to display the control setting menu.
2. Press the **#4 soft key** (PID parameters).
3. Press the **arrow keys** to move the cursor (blue) to the setup item box, press the **soft key** of each value according to the following figure.

The numerical values such as the SP are entered using the pop-up window that appears by pressing the Input soft key.

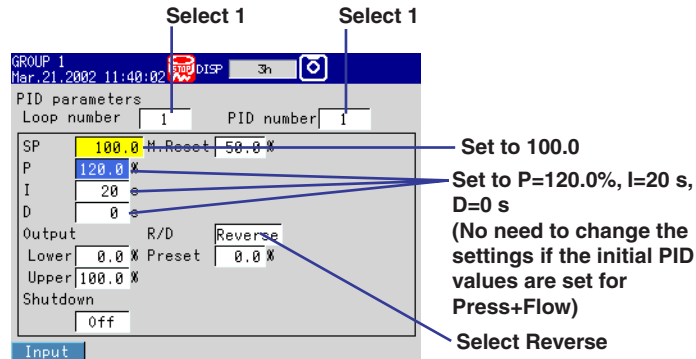

4. Press the **DISP/ENTER key** to confirm the settings.

Control Setup Example 4: ON/OFF Control

Object of Control and Description

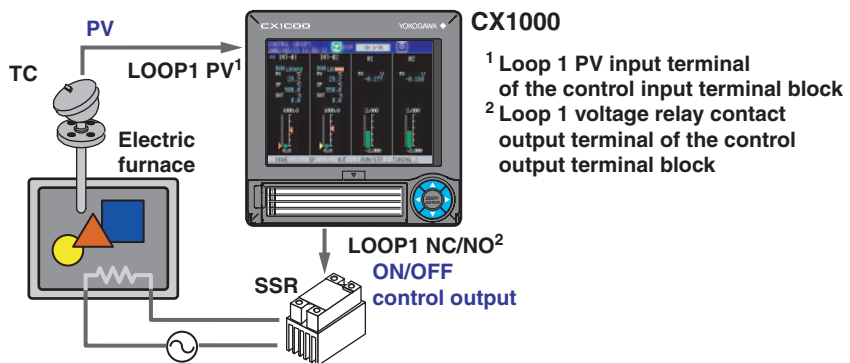

- Loop number: 1
- Control direction: Reverse
- Relay hysteresis Setpoint: 10.0, activation position: center
- Input type: TC K type
- Measurement span: 0 to 1200°C
- Output type: ON/OFF control output
- Temperature setpoint: 700°C

Basic Control Settings

1. Show the basic control setting menu.
See "Control Setup Example 1" for the steps to show the menu.

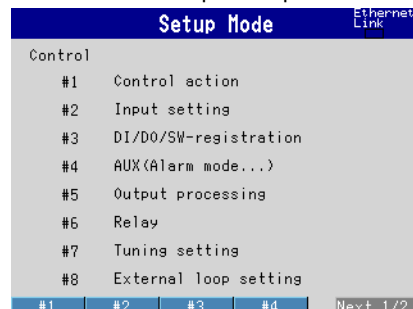

Examples of Control Setup Operation

2. Press the **#1 soft key** (Control action, Input setting).
3. Press the **arrow keys** to move the cursor (blue) to the setup item box, press the **soft key** of each value according to the following figure, and press the **DISP/ENTER key**.

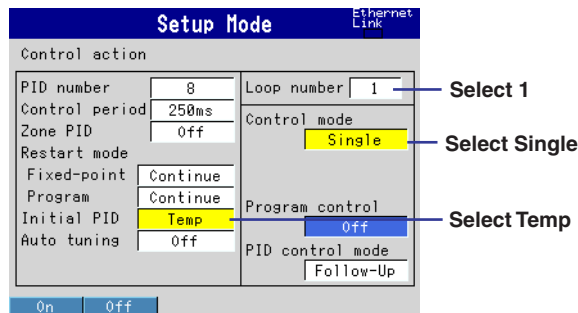

4. Press the **ESC key** to return to the basic control setting menu.
5. Press the **#3 soft key** (Output processing).
6. Press the **arrow keys** to move the cursor (blue) to the setup item box, press the **soft key** of each value according to the following figure, and press the **DISP/ENTER key**.

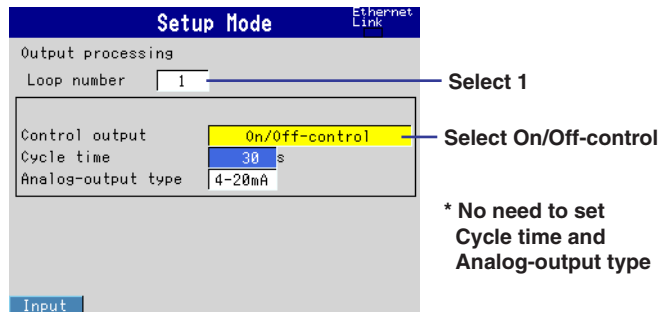

7. Press the **DISP/ENTER key** to confirm the settings.
8. Press the **ESC key** twice to return to the menu display (basic setting mode 3/4).
9. Press the **Next 3/4 soft key** to show the menu display (basic setting mode 4/4).
10. Press the **End soft key**.

A confirmation window opens.

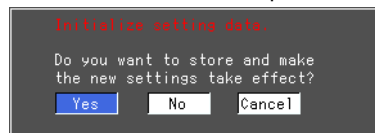

11. Press the **DISP/ENTER key** to confirm the settings.

Setting the Control Input Range in Setting Mode

1. From the operation display, click the **MENU** key to display the control setting menu shown below.

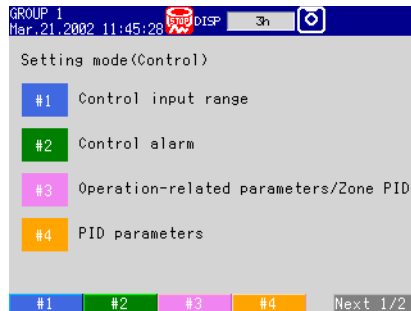

2. Press the **#1** soft key (Control input range).
3. Press the **arrow keys** to move the cursor (blue) to the setup item box, press the **soft key** of each value according to the following figure. The numeric values of the lower/upper limit of range are entered using the pop-up window that appears by pressing the Input soft key.

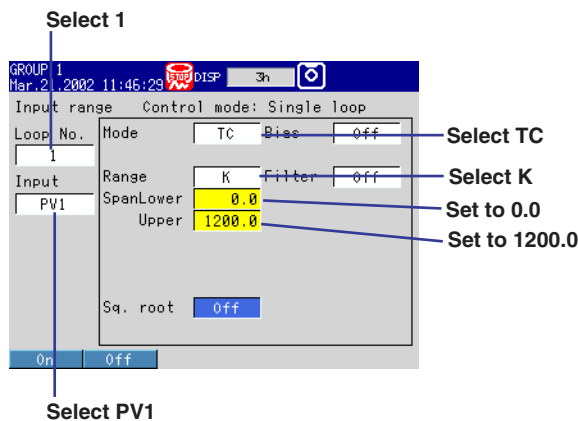

4. Press the **DISP/ENTER** key. A confirmation window shown below opens.
5. Press the **DISP/ENTER** key to confirm the settings.

Setting Control Parameters in Setting Mode

1. From the operation display, click the **MENU** key to display the control setting menu.
2. Press the **#4** soft key (PID parameters).
3. Press the **arrow keys** to move the cursor (blue) to the setup item box, press the **soft key** of each value according to the following figure. The numeric values of the target setpoint and relay hysteresis setpoint are entered using the pop-up window that appears by pressing the Input soft key.

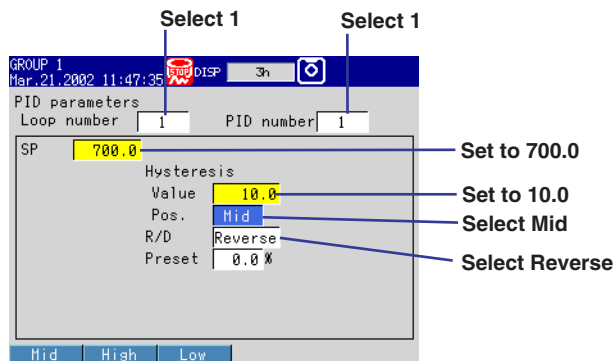

4. Press the **DISP/ENTER** key to confirm the settings.

Setting the Display Items on the Control Group Display (Control Group Setting)

Below are the procedures for displaying loops 1 and 2 and measurement channel (input channel for measurement) 1 and 2 on the control group display (group name: CONTROL GROUP 1) of group number 1.

1. From the operation display, click the **MENU key** and then the **Next 1/2 soft key** to display the control setting menu 2/2 shown below.

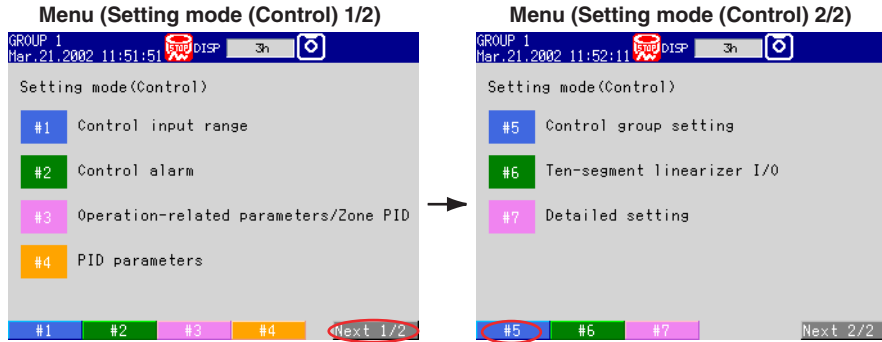

2. Press the **#5 soft key** to show the Control group setting display.
3. Press the **arrow keys** to move the cursor (blue) to the setup item box, press the **soft key** of each value according to the following figure.

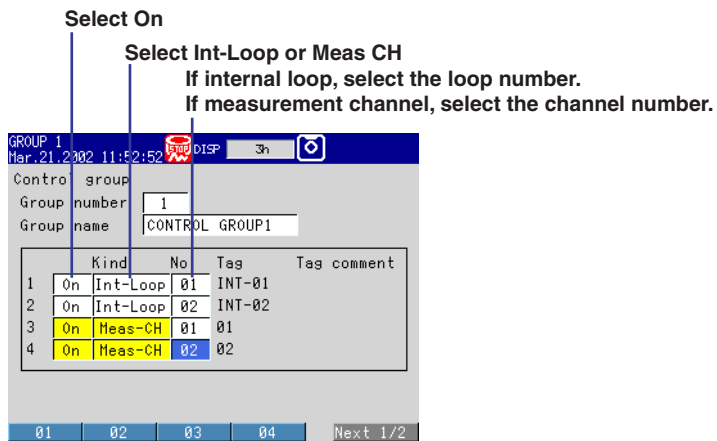

4. Press the **DISP/ENTER key** to confirm the entry.

Control Group Display Example after Setup

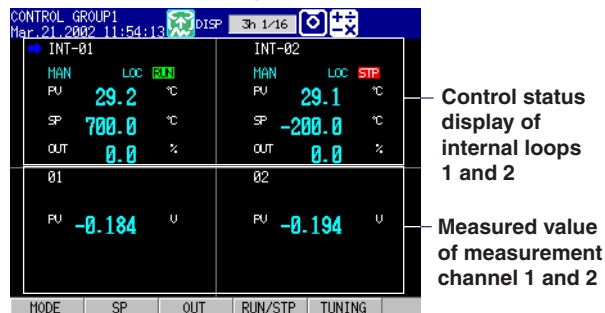

Displaying the Trend of PV, SP, and OUT Values

Below are the procedures for displaying the trends of PV, SP, and OUT of loop 1 and the values of measurement channels 1 and 2 on the trend display of group number 1 (group name: GROUP 1).

- From the operation display, open the Group set, Trip line setting display according to the following procedure.
Press the **MENU key** (to switch to Setting mode (Control)) and then the **MENU key** (switch to Set mode). Press the **#4 soft key** (to select Display) and then the **#1 soft key** (to select Group set, Trip line).

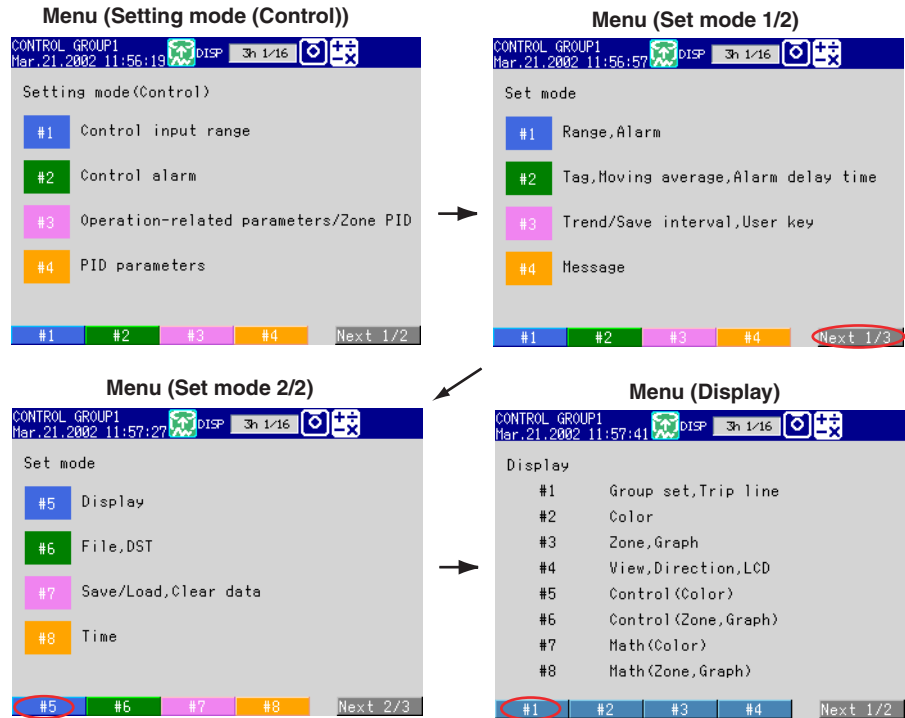

- Press the **arrow keys** to move the cursor (blue) to the Channel setting box.

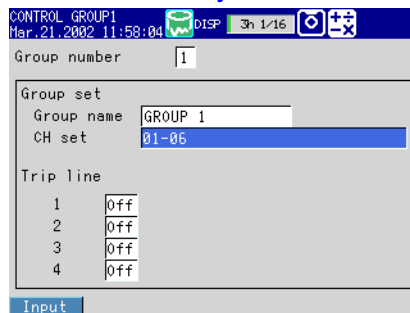

- Press the **Input soft key** to open the channel input pop-up window.
- Use the **arrow keys** and the **DISP/ENTER key** to select the channels to include in the group.

In this group setting, the PV, SP, and OUT of loop 1 are assigned channel numbers 101, 102, and 103, respectively. To include PV, SP, and OUT of loop 1, enter 101-103 or 101.102.103. For measurement channels 1 and 2, enter 01.02.

Displaying the Trend of PV, SP, and OUT Values

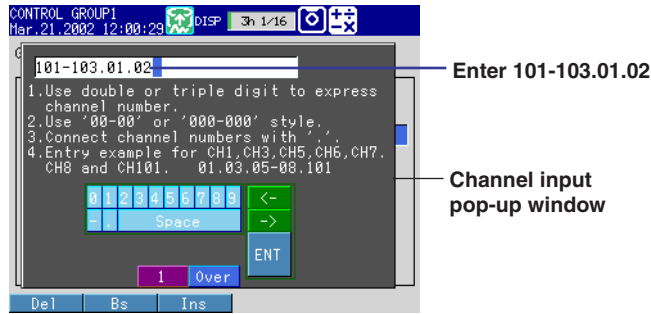

5. Select the ENT key on the channel input pop-up window and press the **DISP/ENTER** key.

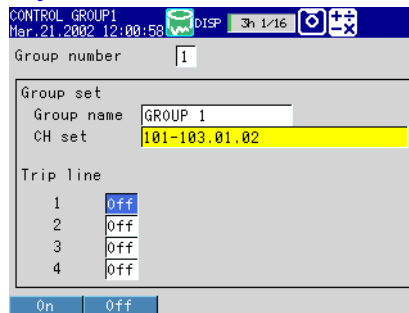

6. Press the **DISP/ENTER** key to confirm the entry.

Note

You can select up to 10 channels from measurement channels (CH1 to CH06), computation channels (CH31 to CH42), internal control channels (CH101 to CH106), and external control channels (CH201 to CH212) using Channel setting.

- Assignment of internal control channels (channels of internal loops)
 - The data of two loops is assigned to channel numbers as follows:
 - Loop 1 PV: 101, Loop 1 SP: 102, Loop 1 OUT: 103
 - Loop 2 PV: 104, Loop 2 SP: 105, Loop 2 OUT: 106
- Assignment of external control channels (channels of external loops)
 - The data of four loops is assigned to channel numbers as follows:
 - External loop 1 PV: 201, External loop 1 SP: 202, External loop 1 OUT: 203
 - External loop 2 PV: 204, External loop 2 SP: 205, External loop 2 OUT: 206
 - External loop 3 PV: 207, External loop 3 SP: 208, External loop 3 OUT: 209
 - External loop 4 PV: 210, External loop 4 SP: 211, External loop 4 OUT: 212

Set the channels to assign them to a group according to the following rules.

- Enter the channel number using two or three digits.
- Separate each channel with a period.
- Use a hyphen to specify consecutive channels.

Trend Display Example after Setup

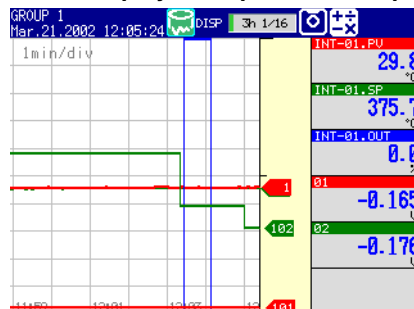

Switching the Operation Mode

For details on the procedure for switching the operation mode, see chapter 6, “Operations during Control Operation” in the *CX1000 User’s Manual (IM 04L31A01-03E)*. The following is a procedural example on the control group display.

Run/Stop Operation

For cascade control, the following operations can be performed only when the secondary loop is selected.

1. Use the **arrow keys** to move the cursor to the desired control loop.



2. Press the **RUN/STP soft key**.

A pop-up window for running and stopping the operation appears.

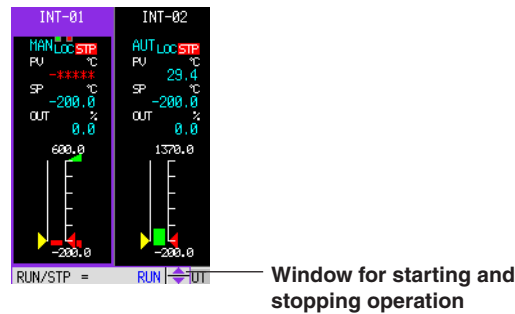

3. Select RUN or STOP using the **up and down arrow keys**.
4. Press the **DISP/ENTER key** to confirm the changes.

Switching between Auto, Manual, and Cascade Control

You can only switch to the cascade mode on the secondary loop of cascade control.

1. Use the **arrow keys** to move the cursor to the desired control loop.
2. Press the **Mode soft key**.

The MODE selection pop-up window appears.

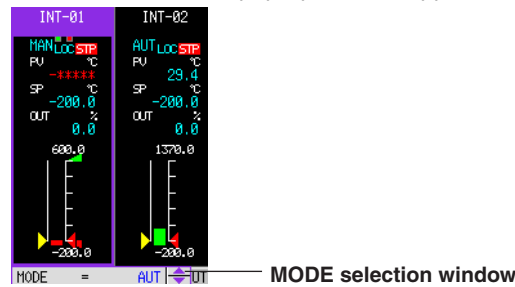

3. Select AUT (auto), MAN (manual), or CAS (cascade) using the **up and down arrow keys**.
4. Press the **DISP/ENTER key** to confirm the changes.

Changing the Target Setpoint

1. Use the **arrow keys** to move the cursor to the desired control loop.
2. Press the **SP soft key**.

The SP modification pop-up window appears. The window shows the current target setpoint.

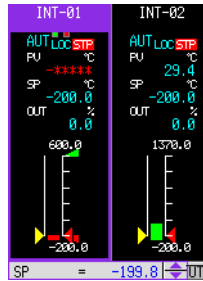

Window for changing the target setpoint

3. Change the target setpoint using the up and down arrow keys.
4. Press the **DISP/ENTER key** to confirm the changes.

Changing the Control Output

The following operation cannot be performed during auto operation, when operation is stopped, or when the primary loop of cascade control is selected. When the operation is stopped, the preset value is output.

1. Use the **arrow keys** to move the cursor to the desired control loop.
2. Press the **OUT soft key**.

The OUT modification pop-up window appears. The window shows the current control output.

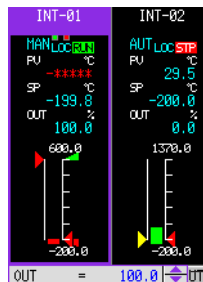

Window for changing the control output

3. Change the control output using the up and down arrow keys. The control output is set to the new value at this point.
4. Press the **DISP/ENTER key** to complete the procedure.

Switching between Remote and Local Modes

The soft key menu does not show REM/LOC, if Control > Contact input-registration/ AUX(Alarm mode... > Remote setting is set to Off. Remote input cannot be used for the target setpoint when the secondary loop of cascade control is selected or during program control. Thus, there is no remote/local switching in these cases.

1. Use the **arrow keys** to move the cursor to the desired control loop.
2. Press the **REM/LOC soft key**.

A pop-up window for switching between remote and local appears.



Window for switching between remote and local

3. Select REMOTE or LOCAL using the **up and down arrow keys**.
4. Press the **DISP/ENTER key** to confirm the changes.

Switching between Automatic and Manual for the Analog Retransmission Loop

You can switch the output mode for the control loop specified for analog retransmission. When set to AUTO, the computed result of analog retransmission is output. When set to MAN, you can set the direct output value.

1. Use the **arrow keys** to move the cursor to the desired control loop.
2. Press the **[MODE] soft key**.

A pop-up window switching between auto and manual appears.

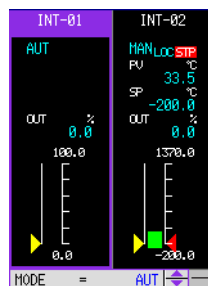

Auto/manual switching window

3. Select AUTO or MAN using the **up and down arrow keys**.
4. Press the **DISP/ENTER key** to confirm the changes.

Changing the Analog Retransmission Output

MAN must be set for the MODE using the procedure above.

1. Use the **arrow keys** to move the cursor to the desired control loop
2. Press the **[OUT] soft key**. The Output Value Setting window appears.

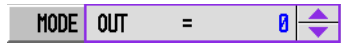

3. Change the output value using the **up and down arrow keys**. The currently set control output value is displayed in the window.

Switching between Automatic and Manual for the DIO Operation Monitoring

You can switch the output mode for the DO specified in the DIO Operation Monitoring Function. When set to AUTO, the internal switch status is output. When set to MAN, you can switch the direct output value between 0 and 1.

1. Use the **arrow keys** to move the cursor to the desired control loop.
2. Press the **[MODE] soft key**.

A pop-up window switching between auto and manual appears.

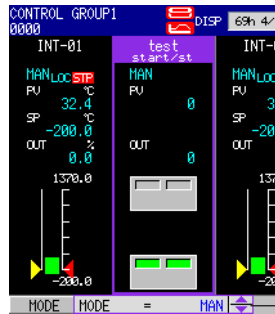

Auto/manual switching window

3. Select AUTO or MAN using the **up and down arrow keys**.
4. Press the **DISP/ENTER key** to confirm the changes.

Tuning Operation

For details on the procedure of switching the operation mode, see chapter 6, “Operations during Control Operation” in the *CX1000 User's Manual (IM 04L31A01-03E)*.

Displaying the Tuning Display

Press the **TUNING soft key** on the control group display.

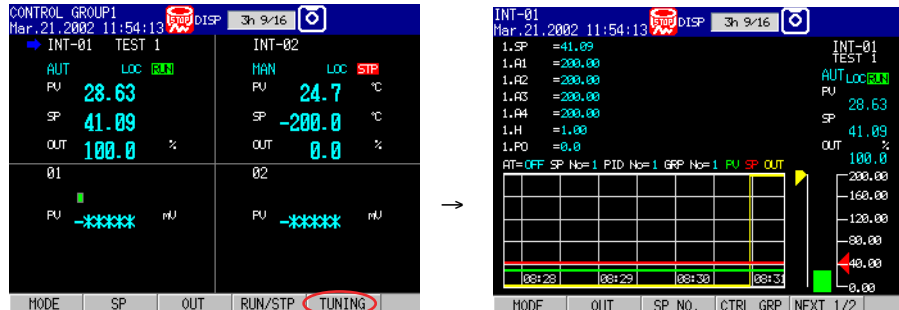

Auto Tuning

To execute auto tuning, Basic setting mode > #10 Control > #1 Control action, Input setting > Auto tuning must be turned On before carrying out the following procedure.

1. Press the **AUTO TUN soft key** on the tuning display.

As shown in the following figure, the auto tuning setup pop-up window appears along with a warning message.

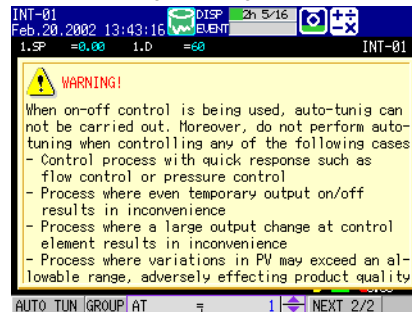

Auto tuning setup window

2. Select the control loop using the up and down arrow keys.
3. Press the **DISP/ENTER key** to execute auto tuning.

CAUTION

- You cannot execute auto tuning during ON/OFF control.
- Do not execute auto tuning when controlling the following types of processes. If you do, malfunction may occur in the control process.
 - Control process with fast response such as flow control and pressure control.
 - Processes that result in adverse consequences when the output is turned on/off even if temporarily.
 - Processes that result in adverse consequences if a large output change is applied to the control element.
 - Processes that may cause adverse effects on the quality of a product when the process value exceeds the allowed fluctuation width.

Manual Tuning

1. Press the **arrow keys** on the tuning display.
A cursor appears in the control parameter display section.
2. Select the control parameter you wish to change using the **arrow keys**.
3. Press the **DISP/ENTER key**.
The parameter modification pop-up window appears.

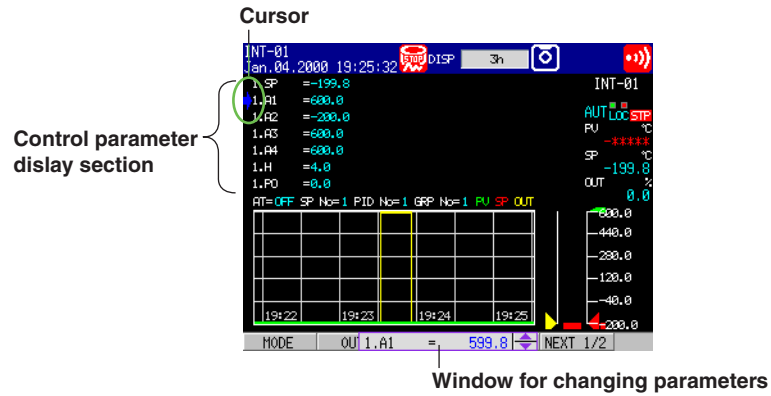

4. Change the value using the up and down arrow keys.
5. Press the **DISP/ENTER key** to confirm the changes.
To close the window without making any changes, press the ESC key.

Program Control Function (/PG1 and /PG2 Options)

Program Control Function Introduction

Program control function is used to ramp-up or ramp-down the SP according to a program pattern. The number of program patterns that you can create with the CX1000 is as follows:

- /PG1 option: 4
- /PG2 option: 30

Up to 99 segments can be specified in a single pattern.

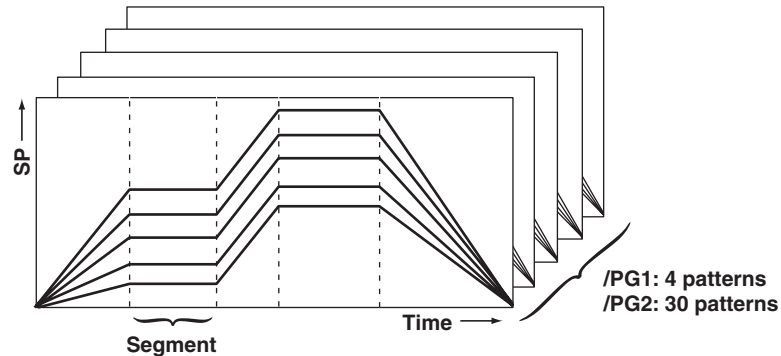

Operation Mode during Program Control

The following 4 types of operation modes are available.

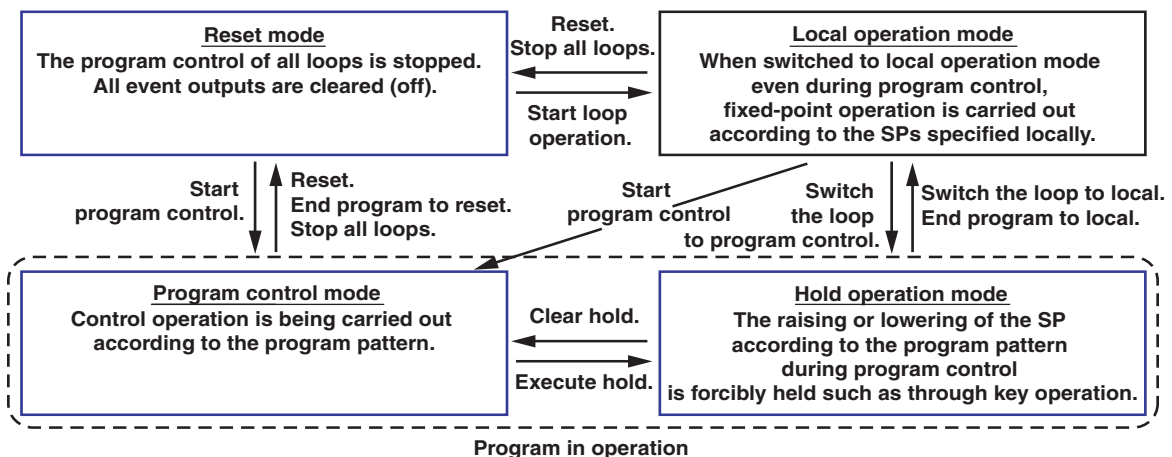

Operations on the Program Selection Display (See the figure on the next page)

Displaying the Program Selection Display

On the control group display or control overview display, select **CONTROL** > **PROGRAM** from the screen selection menu.

Starting Program Control

Program control starts, and the screen switches to the Program Control Display.

1. On the Program Selection Display, press the **RUN** soft key.

A pop-up window for starting the program control appears.



2. Press the **DISP/ENTER** key.

Program Selection Display Example

Program pattern name — Pattern 1
 Apr. 07, 2002 11:17:44 DISP 69h 16/16

Repeat frequency — 200.0
 160.0
 120.0
 80.0
 40.0
 0.0

Preset pattern waveform

The selected segment — (circled in blue)

Selected pattern number — 01

Selected segment* number — 01

Selected segment* time — 00:50:00

Target SP display of the selected segment* — 50.0 °C

Segment range to be repeated — INT-01 TSP

Start segment number display — INT-02 TSP

Display the program pattern control start delay time — 200.0

Pattern details:
 PATTERN NO: 01<01> REPEAT: 001<01-01>
 SEGMENT NO: 01/11 START SEG: 01
 SEGMENT TIME: 00:50:00 DELAY TIME: 00:00:00

Buttons: RUN | PT NO: | SET PTNO | RUN PNL | NEXT 1/4

*** The selected segment is the segment displayed at the left end. Select the segment using the left and right arrow keys.**

Show the program control display (valid only during program control)
Settings for pattern to be run as a result of communication function, DI/DO, or internal switch action
Switch the program pattern
Display the window for starting the program control

Soft key menu 2/4
 EV ON/OFF | EV KIND | OVERVIEW | CTRL GRP | NEXT 2/4

Turns the event display ON/OFF (style number S3 or later)
Switches to control group display (style number S3 or later)
Switches to overview display (style number S3 or later)
Display the window for the selection menu for the event display method (style number S3 or later)

Soft key menu 3/4
 ST SEG | DELAY TM | ALL/DIV | DSP LOOP | NEXT 3/4

Turns the event display ON/OFF (style number S3 or later)
Switch full display/split display
Display the window for setting the program pattern control start delay time
Display the window for setting the program pattern start segment

Soft key menu 4/4
 -10SEG | +10SEG | TAG/CHT | NEXT 4/4

Shift the displayed segment by +10 segments
Shift the displayed segment by -10 segments
Switch tag/tag comment display

Operations on the Program Control Display (See the figure on the next page)

Displaying the Program Control Display

When you start the program control on the program selection display, the program control display appears. You can display the program control display when program control is in progress by selecting **CONTROL > PROGRAM** from the display selection menu on the control group display or the control overview display or pressing the **RUN PNL soft key** on the program selection display.

Executing and Clearing the Hold Operation

You can hold the progress of the program (stop the timer). While in hold, you can change the segment SP or increase or decrease the remaining segment time.

1. Press the **HOLD soft key**.

A pop-up window for executing/clearing the hold operation appears.

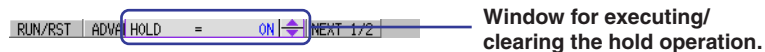

2. Select ON (execute) or OFF (clear) using the **up and down arrow keys**.
3. Press the **DISP/ENTER key**.

Resetting Program Control

Resets the program control and stops.

1. Press the **RUN/RST soft key**.

A pop-up window for starting and resetting program control appears.

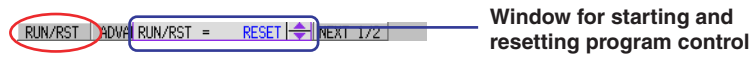

2. Select RESET using the **up and down arrow keys**.
3. Press the **DISP/ENTER key**.

Program Control Display Example

Cursor indicating the program execution position

Control pattern number display

Program pattern name

Preset pattern waveform (SP, dotted line)

PV waveform (solid line)*

Control segment number

Control mode

HOLD (blinking): Hold mode
 WAIT: Wait mode
 DELAY: Program pattern controlled being delayed

Tag/Tag comment display

PV, SP, and OUT display

Displays wait time when in wait mode

Repeat frequency and repeat count values

Repeat segment range

Remaining time display of the control segment

Show the program selection display

Advance the program

Display the window for starting program control and resetting

Soft key menu 2/3
 EV ON/OFF | EV KIND | OVERVIEW | CTRL_GRP | NEXT 2/3

Switch to control group display (style number S3 or later)
 Switch to overview display (style number S3 or later)
 Display the selection menu for the event display method (style number S3 or later)
 Turn the event display ON/OFF(style number S3 or later)

Soft key menu 3/3
 ALL/DIV | DSP_LOOP | TAG/CHT | NEXT 3/3

Switch tag/tag comment display
 Display the ON/OFF selection menu of program pattern display loops
 Switch full display/split display

Soft key menu when in hold mode
 RUN/RST | ADVANCE | HOLD | SEG.TIME | NEXT 1/3

Display the window for changing the remaining segment time

TSP_CHG | SEL_PNL | EV_ON/OFF | EV_KIND | NEXT 2/4

Display the menu for selecting the loop of which the target SP is to be changed

OVERVIEW | CTRL_GRP | ALL/DIV | DSP_LOOP | NEXT 3/4

TAG/CHT | NEXT 4/4

* PV waveforms are displayed when you press the START key to start the data acquisition to the internal memory.

Switching between Program Control and Local Control for Each Loop

Press the **PRG/LOC soft key** on the control group screen to switch between program and local.

Executing Several Program Patterns

You can execute multiple program patterns whose loop numbers do not overlap.

Switching Pattern Numbers

1. Press the **[PT NO.] soft key** in the program selection screen.
The pattern number switching pop-up window appears. The currently set pattern numbers are displayed in the window.
2. Select a pattern number using the up and down arrow keys.
3. Press **DISP/ENTER key** to confirm the changed settings.
To close without saving, press the ESC key.

Program Operation Start

1. Press the **[RUN] soft key**.
The program operation start pop-up window appears.
2. Press the **DISP/ENTER key**. The screen changes to the program operation display.

Displaying the Program Selection Display

1. Press the **[SEL PNL] soft key**.
The screen changes to the program selection display.

Executing a Separate Program Pattern

1. Repeat the above procedure as necessary.

Switching the Displayed Pattern in the Program Operation Display

1. Press the left or right arrow keys to switch the displayed pattern.

Program Control Setup Operation

Program Control Setup Operation Sequence

First, set the control functions of the loops to be used (see below). Next, set the program control (see page 37).

Setting the Control Operation of the Loops to Be Used

This section explains only the settings specific to the program control.

- **Control > [Control action, Input setting] setup screen**

For a description of the setup procedure, see pages 11 and 12.

The screenshot shows the 'Setup Mode' screen for 'Control action'. The screen is divided into two columns. The left column contains: PID number (8), Control period (250ms), Zone PID (Off), Restart mode (Continue), Fixed-point (Continue), Program (Temp), Initial PID (Off), and Auto tuning (Off). The right column contains: Loop number (1), Control mode (Single), Program control (On), and PID control mode (Follow-Up). At the bottom, there are four numbered buttons (1, 2, 3, 4) and a 'Next 1/2' button. A blue arrow points from the 'Program control' field to a text box on the right. Another blue arrow points from the 'PID control mode' field to a text box below it.

Select the operation status when a power failure occurs during program control and the power recovers.

- [Continue]: Continues program control.
- [Manual]: Switches the loop to manual operation.
- [Reset]: Resets program control.

Select [On].

Program Control Related Setup Operations

Follow the flow chart below.

For further details on each function, see section 1.11, "Program Control Related Settings" in the *CX1000 User's Manual (IM 04L31A01-03E)* provided on the accompanying CD-ROM.

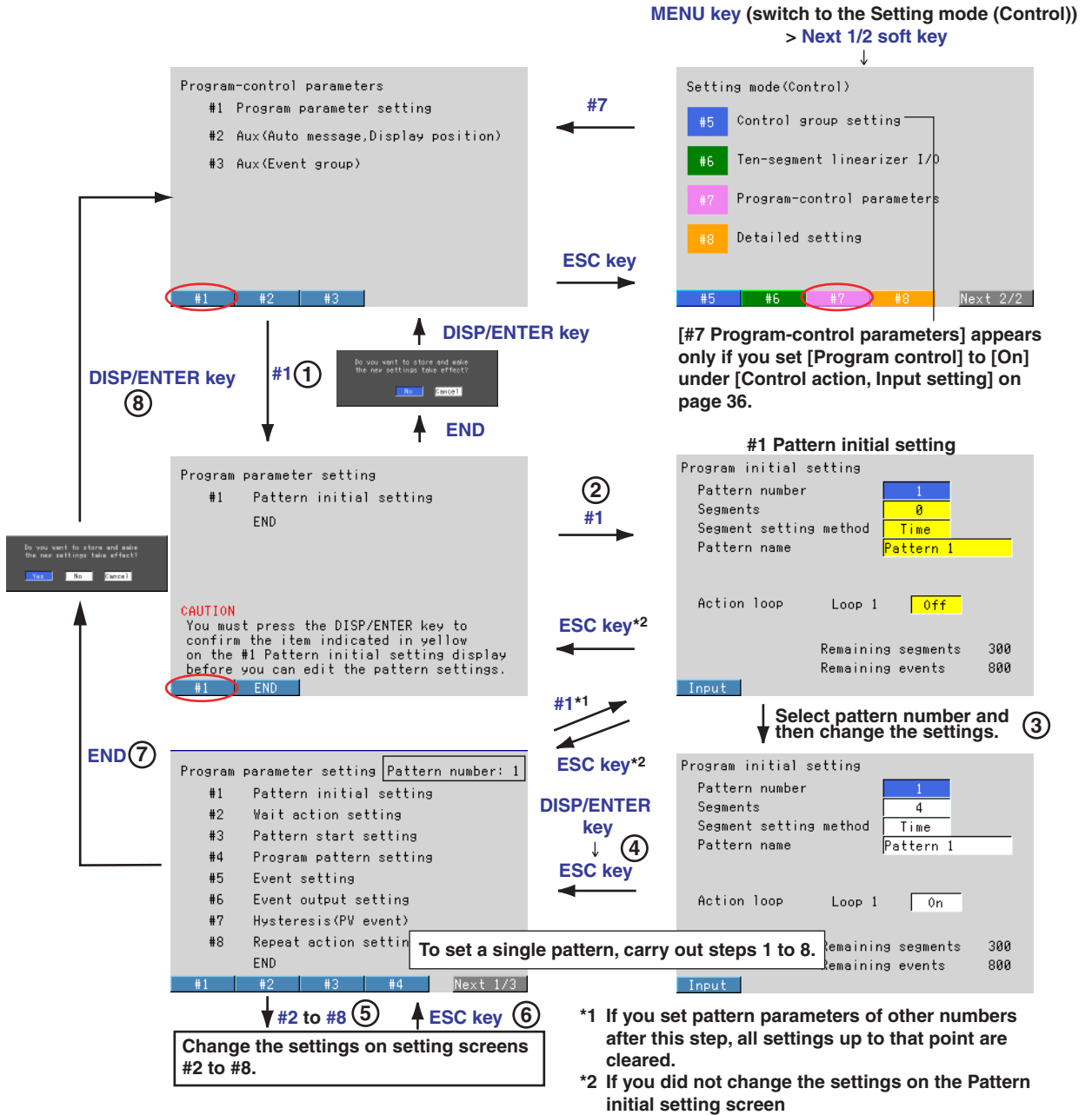

Setup Sequence

- First, enter pattern initial settings (1 to 4 above).
- Next, set [#2 Wait action setting] through [#8 Repeat action setting] (5 and 6 above).
- Return to the Program-control parameters screen (7 and 8 above).
- Set [#2 Aux (Auto message, Display position).] and [#3 Aux (Event group).]

Refer to the figure above for the following procedures.

Program Control Function (/PG1 and /PG2 Options)

Pattern Initial Setting

Enter the program pattern number.
/PG1: 1 to 4, /PG2: 1 to 30

Enter the number of segments to be used.
1 to 99

Select the time or ramp-rate (see below).

Enter the pattern name (up to 16 characters).

Specify the position of the segment to be deleted or added.

Segment setting method: Time

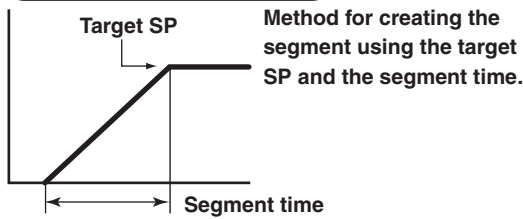

Segment setting method: Ramp-rate

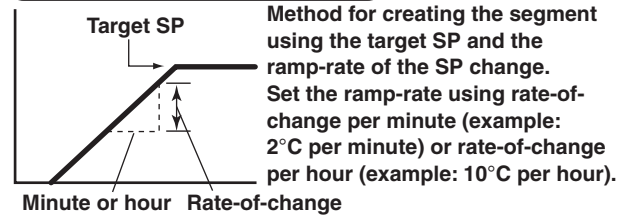

Wait Action Setting

Set 5 types of wait actions. Specify the wait action for each segment.

Wait zone number

Select [On] to set a wait zone.

Set the wait zone (engineering unit).

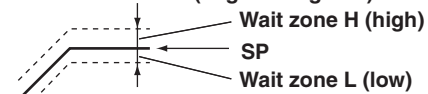

Enter the maximum wait time when using the wait function at the time of segment switching (see below).

Wait function at the time of segment switching

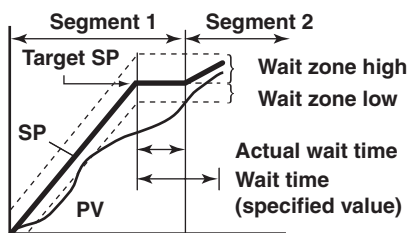

If the PV is outside the wait zone when the SP reaches the target SP of the segment, the program does not advance to the next segment. When the PV enters the wait zone, the program advances to the next segment. In addition, when the wait time elapses even if the PV does not enter the wait zone, the program advances to the next segment. If the wait zone is set to 00:00:00, the program does not advance to the next segment until the PV reaches the wait zone.

Wait function within the segment

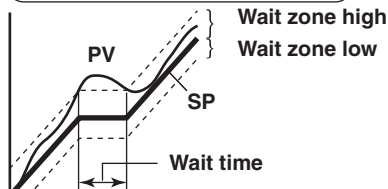

The advancing of the program control stops when the SP exits from the wait zone. When the PV returns within the wait zone, the advancing of the program control resumes. [Segment time] setting is irrelevant for wait within the segment. The advancing of the program control is stopped until the PV reaches the wait zone.

Pattern Start Setting

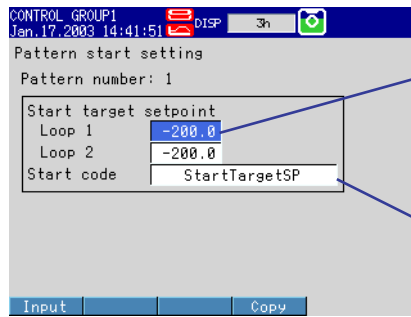

Enter the SP of the pattern start point.

Select the operation when starting the program control (see below).

Select the operation start condition (Start code) from the following.

Start code: StartTargetSP

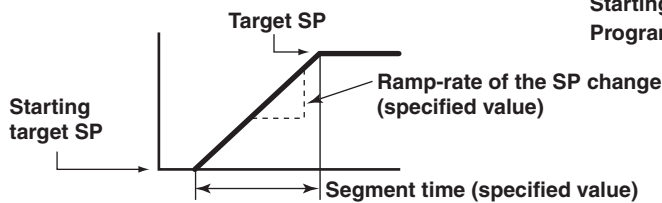

Starting SP Start
Program starts from the starting target SP.

Start code: RampPV1Start to RampPV6Start

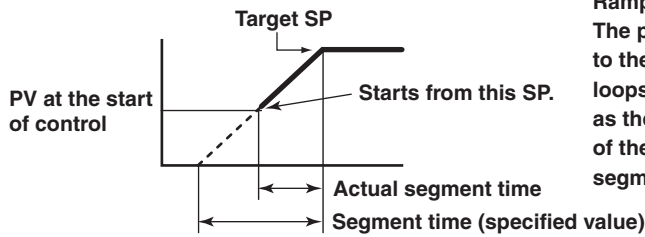

Ramp-prioritized PV1 to PV6 start
The program control starts from the SP corresponding to the PV (PV1 to PV6) of the specified loop. For other loops, the program control starts from the same point as the start point of the specified loop. The ramp-rate of the SP change is maintained as specified. The segment time is shortened.

Start code: TimePVStart

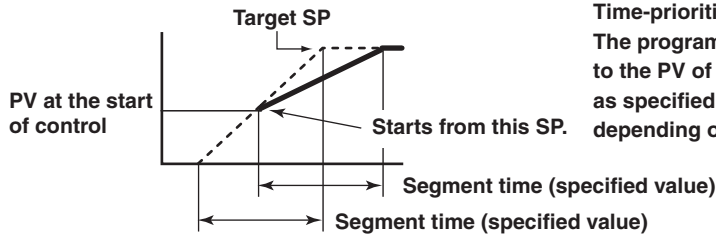

Time-prioritized PV start
The program control starts from the SP corresponding to the PV of each loop. The segment time is maintained as specified. The ramp-rate of the SP change varies depending on the position of the PV.

Program Pattern Setting

- When the segment setting method is set to [Time]

- When the segment setting method is set to [Ramp]

Event Setting

- When the event kind is set to [TimeEvent]

Time event is a function used to turn ON or OFF the contact output after a specified time elapses by starting the clock from the time the segment operation is started.

TimeEvent

Up to 16 time events can be specified for each segment. There are 3 types of time events.

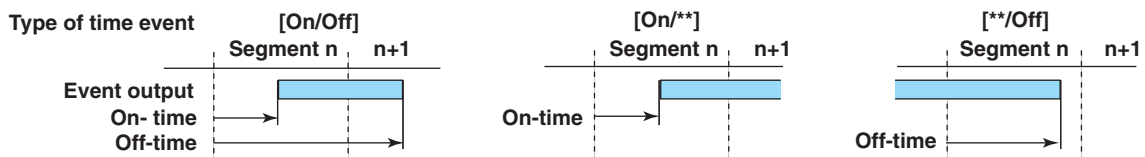

• When the event kind is set to [PVEvent]

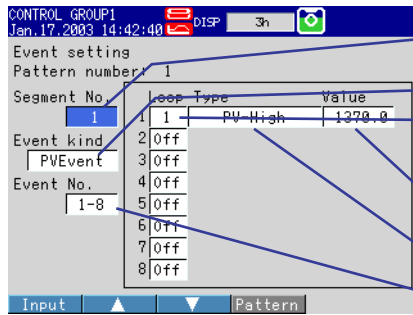

- Select the segment number to which the event is to be assigned.
- Select [PVEvent] (see below).
- Select the loop to which the event is to be assigned.
- Enter a value when the PV event is to be detected using engineering unit.
- Select the type of PVEvent (see below).
- Select the event number range, [1-8] or [9-16].

This function outputs preset alarms such as PV alarms, SP alarms, and output alarms during program operation. Up to 16 PV events can be specified for each segment. PV events operate only within the specified segment.

PV event

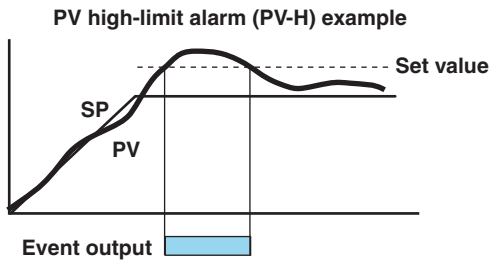

- Select the type of PV events from the following.
- PV-H (PV high-limit), PV- L (PV low-limit), Dev-H (deviation high-limit), Dev-L (deviation low-limit), Dev-H&L (deviation high & low limit), and D-W-H&L (deviation within high & low limits)
 - SP-H (SP high-limit) and SP-L (SP low-limit)
 - Out-H (output high-limit) and Out-L (output low-limit)

Event Output Destination Setting

The even output destination is set using the Event output setting display (see [Program-control parameters] display on page 37).

Repeat Action Setting

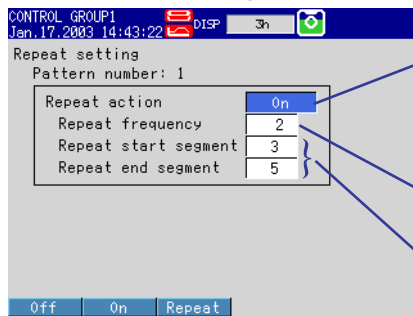

- Select [On] or [Repeat] when using the repeat action.
 - [On]: Repeats the specified number of times
 - [Repeat]: Repeats infinitely
- Enter the number of repetitions when [Repeat action] is set to [On].
- Set the range of segments to be repeated.

Repeat action

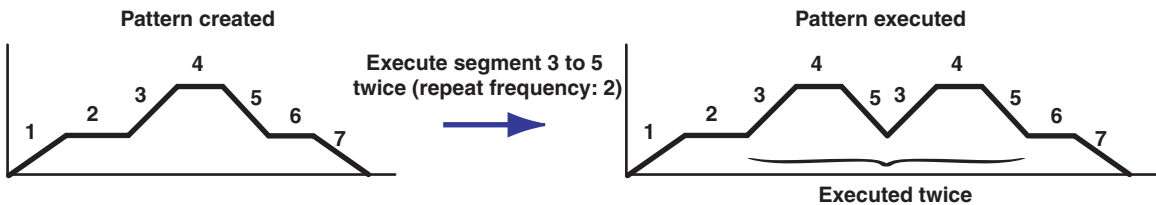

List of Parameters

Below is a list of parameters for the model with the various function options. However, settings related to the program control function option are not given.

Basic Setting Mode

#1 Alarm

Parameter	Selectable Range or Selections	Initial Value
Alarm > Reflash	On/Off	Off
Alarm > Relay > AND	None, I01, I01-I02, I01-I03, ... , or I01-I06	None
Alarm > Action	Energize or Deenergize	Energize
Alarm > Behavior	Hold or Nonhold	Nonhold
Alarm > Indicator	Hold or Nonhold	Nonhold
Alarm > Rate of change > Increase/Decrease	1 to 15	1
Alarm > Hysteresis	On/Off	On

#2 A/D, Temperature

Parameter	Selectable Range or Selections	Initial Value
A/D Integrate > Integrate	Auto, 50 Hz, 60 Hz, or 100 ms	Auto
A/D > Scan interval	1 s or 2 s	1 s
A/D > First-CH	01 to 06	01
A/D > Last-CH	01 to 60	01
A/D > Burnout set	Off, Up, or Down	Off
A/D > RJC	Internal or External	Internal
A/D > Volt (μ V)	-20000 μ V to 20000 μ V	0 μ V
Temperature > Unit	C or F	C

#3 Memory

Parameter	Selectable Range or Selections	Initial Value
Memory > Save	Manual or Auto	Auto
Memory > Data	Display, E+D, or Event	Display
Memory > Event > Sample rate	1 s, 2 s, 5 s, 10 s, 30 s, 60 s, 120 s, 300 s, or 600 s	1 s
Memory > Event > Mode	Free, Trigger, or Repeat	Trigger
Memory > Event > Block	1, 2, 4, 8, or 16	1
Memory > Event > Data length	3 minutes to 31 days	1 h
Memory > Event > Pre-trigger	0, 5, 25, 50, 75, 95, or 100	0
Memory > Event > Trigger > Key	On/Off	On
Memory > Event > Trigger > External	On/Off	Off
Memory > Event > Trigger > Alarm	On/Off	Off

#4 Memory and Trend, Memory Timeup

Parameter	Selectable Range or Selections	Initial Value
Memory and trend > Meas/Math/Loop CH	Meas CH, Math CH, Int CH, or Ext CH	Meas CH
Memory and trend > First-CH	Meas CH: 01 to 06, Math CH: 31 to 42, Int CH : 101 to 106, or Ext CH: 201 to 212	01
Memory and trend > Last-CH	Meas CH: 01 to 06, Math CH: 31 to 42, Int CH : 101 to 106, or Ext CH: 201 to 212	01
Memory and trend > On/Off	On/Off	On
Memory timeup > Timeup type	Off, Hour, Day, Week, or Month	Off
Memory timeup > Date	1 to 28	1
Memory timeup > Time (hour)	0 to 23	0

#5 Keylock

Parameter	Selectable Range or Selections	Initial Value
Keylock > Use/Not	Use/Not	Not
Keylock > Password	Up to 6 alphanumeric characters	-
Keylock > Keys such as START	Free or Lock	Free
Key lock > Soft keys such as ALARM ACK	Free or Lock	Free
Key lock > Control settings such as the input range	Free or Lock	Free

#6 Key login

Parameter	Selectable Range or Selections	Initial Value
Key login > Use/Not	Use/Not	Not
Key login > Auto logout	On/Off	Off
Key login > UserID Use/Not	Use/Not	Not
Key login > Number	1, 2, 3, 4, 5, 6, or 7	1
Key login > On/Off	On/Off	On
Key login > User name	Up to 16 alphanumeric characters	user1
Key login > User ID	Up to 4 alphanumeric characters	1
Key login > Password	Up to 6 alphanumeric characters	–
Key login > setup	On or Off	On

#7 Load, Initialize...

Parameter	Selectable Range or Selections	Initial Value
Load, Initialize > #1 Load settings	–	–
Load, Initialize > #2 Delete	–	–
Load, Initialize > #3 Format	–	–
Load, Initialize > #4 Initialize > Kind	Clear1 to Clear3	Clear3

#8 Option**<#1 Remote>**

Parameter	Selectable Range or Selections	Initial Value
Remote > Action No. 1 to No. 8	None, MemoryStartStop, Trigger, AlarmACK, TimeAdjust, MathStartStop, MathReset, Manual sample, Panel1Load, Panel2Load, Panel3Load, Message1, Message2, Message3, Message4, Message5, Message6, Message7, Message8, Snapshot	None

<#2 Report>

Parameter	Selectable Range or Selections	Initial Value
Report > Report set	Off, Hour, Day, Hour+Day, Day+Week, or Day+Month	Off
Report > Date ¹	1 to 28	1
Report > Day of the week ²	SUN, MON, TUE, WED, THU, FRI, or SAT	SUN
Report > Time(hour)	0 to 23	0
Report > Report CH	R01 to R12	R01
Report > Off/On	On/Off	On
Report > Channel	01 to 06, 31 to 42	01
Report > Sum scale	Off, /s, /min, /h, or /day	/s

¹ When the report type is monthly report

² When the report type is weekly report

<#3 Timer (TLOG)>

Parameter	Selectable Range or Selections	Initial Value
Timer(TLOG) > No.	1 to 3	1
Timer(TLOG) > Mode	Off, Relative, or Absolute	Absolute
Timer(TLOG) > Interval	1 min, 2 min, 3 min, 4 min, 5 min, 6 min, 10 min, 12 min, 15 min, 20 min, 30 min, 1 h, 2 h, 3 h, 4 h, 6 h, 8 h, 12 h, or 24 h	1 h
Timer(TLOG) > Ref.time	0:00 to 23:00	0:00
Timer(TLOG) > Reset	On/Off	Off
Timer(TLOG) > Action	Off or DataSave	Off

List of Parameters

#9 Communication

<#1 Ethernet (IP_Address)>

Parameter	Selectable Range or Selections	Initial Value
Ethernet (IP_Address) > IP-address	–	0.0.0.0
Ethernet (IP_Address) > Subnet mask	–	0.0.0.0
Ethernet (IP_Address) > Default gateway	–	0.0.0.0

<#2 Ethernet (DNS)>

Parameter	Selectable Range or Selections	Initial Value
Ethernet (DNS) > DNS On/Off	On/Off	Off
Ethernet (DNS) > Server search order > Primary	–	0.0.0.0
Ethernet (DNS) > Server search order > Secondary	–	0.0.0.0
Ethernet (DNS) > Host name	Up to 64 alphanumeric characters	–
Ethernet (DNS) > Domain name	Up to 64 alphanumeric characters	–
Ethernet (DNS) > Domain suffix search order > Primary	Up to 64 alphanumeric characters	–
Ethernet (DNS) > Domain suffix search order > Secondary	Up to 64 alphanumeric characters	–

<#3 FTP transfer file>

Parameter	Selectable Range or Selections	Initial Value
FTP transfer file > Disp&Event data	On/Off	Off
FTP transfer file > Report	On/Off	Off

<#4 FTP connection>

Parameter	Selectable Range or Selections	Initial Value
FTP connection	Primary or Secondary	Primary
FTP connection > FTP server name	Up to 64 alphanumeric characters	–
FTP connection > Port number	1 to 65535	21
FTP connection > Login name	Up to 32 alphanumeric characters	–
FTP connection > Password	Up to 32 alphanumeric characters	–
FTP connection > Account	Up to 32 alphanumeric characters	–
FTP connection > PASV mode	On/Off	Off
FTP connection > Initial path	Up to 64 alphanumeric characters	–

<#5 Control (Login, Timeout)>

Parameter	Selectable Range or Selections	Initial Value
Ethernet login > Use/Not	Use/Not	Not
Ethernet login > Level	admin, user1, user2, user3, user4, user5, or user6	admin
Ethernet login > Level > On/Off	On/Off	On
Ethernet login > Level > User name	Up to 16 alphanumeric characters	admin
Ethernet login > Level > Password	Up to 6 alphanumeric characters	0
Application time out > On/Off	On/Off	Off
Application time out > Time	1 to 120	1 min
Keep alive > On/Off	On/Off	On

<#6 Serial, Memory out>

Parameter	Selectable Range or Selections	Initial Value
Serial > Baud rate	1200, 2400, 4800, 9600, 19200, or 38400 bps	9600 bps
Serial > Data length	7 or 8	8 bit
Serial > Parity	Odd, Even, and None	Even
Serial > RS-232 > Handshaking	Off:Off, XON:XON, XON:RS, or CS:RS	Off:Off
Serial > RS-422/485 > Address	1 to 32	1
Serial > RS-422/485 > Protocol	Normal, Modbus, Modbus-M, or Ladder	Normal
Memory output	Ethernet or serial	Ethernet

<#7 Modbus master (BASIC)>

Parameter	Selectable Range or Selections	Initial Value
Basic settings > Read cycle	125 ms, 250 ms, 500 ms, 1 s, 2 s, 5 s, 10 s, 15 s, 20 s, or 30 s	2 s
Basic settings > Timeout	125 ms, 250 ms, 500 ms, 1 s, 2 s, 5 s, 10 s, or 1 min	2 s
Basic settings > Retrials	Off, 1, 2, 3, 4, 5, 10, or 20	1

<#8 Modbus master (COMMAND)>

Parameter	Selectable Range or Selections	Initial Value
Command settings > 1 to 8	On/Off	Off
Command settings > 1 to 8 > First-CH, Last-CH	C01 to C30	C01, C01
Command settings > 1 to 8 > Address	1 to 247	1
Command settings > 1 to 8 > Slave Registers	Input registers: 30001 to 39999, 300001 to 365535 Hold registers: 40001 to 49999, 400001 to 465535	30001
Command settings > 1 to 8 > Type	INT16, UINT16, INT32_B, INT32_L, UINT32_B, UINT32_L, FLOAT_B, or FLOAT_L	INT16

<#9 AUX>

Parameter	Selectable Range or Selections	Initial Value
Recovery Status for Comm. Buffer > DO/SW	Continue, Clear	Clear
Modbus master/Ext loop > Auto recovery	On/Off	Off

#10 Web, E-Mail**<#1 Web>**

Parameter	Selectable Range or Selections	Initial Value
Web > Use/Not	Use/Not	Not
Web > Page type	Operator or Monitor	Operator
Web > On/Off	On/Off	Off
Web > Command	On/Off	Off
Web > Access control	On/Off	Off
Web > User name	Up to 16 alphanumeric characters	–
Web > Password	Up to 6 alphanumeric characters	–

<#2 Basic E-Mail Settings>

Parameter	Selectable Range or Selections	Initial Value
Basic E-Mail settings > SMTP server name	Up to 64 alphanumeric characters	–
Basic E-Mail settings > Port number	0 to 65535	25
Basic E-Mail settings > Recipient 1	Up to 150 alphanumeric characters	–
Basic E-Mail settings > Recipient 2	Up to 150 alphanumeric characters	–
Basic E-Mail settings > Sender	E-mail address assigned by the network administrator (up to 64 alphanumeric characters)	–

<#3 Alarm E-Mail Settings>

Parameter	Selectable Range or Selections	Initial Value
Alarm E-Mail settings > Recipient1	On/Off	Off
Alarm E-Mail settings > Recipient2	On/Off	Off
Alarm E-Mail settings > Alarm1 to 4	On/Off	Off
Alarm E-Mail settings > Include INST	On/Off	Off
Alarm E-Mail settings > Include source URL	On/Off	Off
Alarm E-Mail settings > Subject	Up to 32 alphanumeric characters	(CX) Alarm_summary
Alarm E-Mail settings > Header1	Up to 64 alphanumeric characters	–
Alarm E-Mail settings > Header2	Up to 64 alphanumeric characters	–

List of Parameters

<#4 Scheduled E-Mail Settings>

Parameter	Selectable Range or Selections	Initial Value
Scheduled E-Mail settings > Recipient1	On/Off	Off
Scheduled E-Mail settings > Interval	1 h, 2 h, 3 h, 4 h, 6 h, 8 h, 12 h, or 24 h	24 h
Scheduled E-Mail settings > Ref.time	00:00 to 23:59	00:00
Scheduled E-Mail settings > Recipient2	On/Off	Off
Scheduled E-Mail settings > Interval	1 h, 2 h, 3 h, 4 h, 6 h, 8 h, 12 h, or 24 h	24 h
Scheduled E-Mail settings > Ref.time	00:00 to 23:59	00:00
Scheduled E-Mail settings > Include INST	On/Off	Off
Scheduled E-Mail settings > Include source URL	On/Off	Off
Scheduled E-Mail settings > Subject	Up to 32 alphanumeric characters	(CX) Periodic_data
Scheduled E-Mail settings > Header1	Up to 64 alphanumeric characters	–
Scheduled E-Mail settings > Header2	Up to 64 alphanumeric characters	–

<#5 System E-Mail Settings>

Parameter	Selectable Range or Selections	Initial Value
System E-Mail settings > Recipient1	On/Off	Off
System E-Mail settings > Recipient2	On/Off	Off
System E-Mail settings > Include source URL	On/Off	Off
System E-Mail settings > Subject	Up to 32 alphanumeric characters	(CX) System_warning
System E-Mail settings > Header1	Up to 64 alphanumeric characters	–
System E-Mail settings > Header2	Up to 64 alphanumeric characters	–

<#6 Report E-Mail Settings>

Parameter	Selectable Range or Selections	Initial Value
Report E-Mail settings > Recipient1	On/Off	Off
Report E-Mail settings > Recipient2	On/Off	Off
Report E-Mail settings > Include source URL	On/Off	Off
Report E-Mail settings > Subject	Up to 32 alphanumeric characters	(CX) Report_data
Report E-Mail settings > Header1	Up to 64 alphanumeric characters	–
Report E-Mail settings > Header2	Up to 64 alphanumeric characters	–

#11 Aux, Time zone

Parameter	Selectable Range or Selections	Initial Value
AUX > Tag/Channel	Tag/Channel	Tag
AUX > Memory alarm	Off, 1 h, 2 h, 5 h, 10 h, 20 h, 50 h, or 100 h	1 h
AUX > Language	English, Japanese, German, or French	English
AUX > Partial	Use/Not	Not
Time zone > Difference from GMT	–1200 to 1200	0

#12 Control

<#1 Control action>

Parameter	Selectable Range or Selections	Initial Value
Control action > PID number	1 to 8	8
Control action > Control period	250 ms, 500 ms, or 1 s [*]	250 ms
Control action > Zone PID	On/Off	Off
Control action > Restart mode > Fixed-Point	Continue, Manual, or Auto	Continue
Control action > Restart mode > Program	Continue, Manual, or Reset	Continue
Control action > Initial PID	Temp or Press+Flow	Temp
Control action > Auto tuning	On/Off	Off
Control action > Loop number	1 or 2	1
Control action > Control mode	Off, Single, Cascade, or PVSwitching, or Analog retransmission	Single
Control action > Control mode > Method	Range, PVHigh, or Signal	Range
Control action > Program control	On/Off	Off
Control action > PID control mode	Follow-up or Fixed-point	Follow-up

^{*} Fixed to 1 s for A/D integral time of 100 ms.

<#2 Input setting>

Parameter	Selectable Range or Selections	Initial Value
Input setting > Loop number	1 or 2	1
Input setting > Burnout > Measure1	Off, Up, or Down	Up
Input setting > Burnout > Measure2	Off, Up, or Down	Up
Input setting > Burnout > Remote	Off, Up, or Down	Up
Input setting > RJC > Measure1	External or Internal	Internal
Input setting > RJC > Measure1 > Volt (uV)	-20000 to 20000 μ V	0 μ V
Input setting > RJC > Measure2	External or Internal	Internal
Input setting > RJC > Measure2 > Volt (uV)	-20000 to 20000 μ V	0 μ V
Input setting > RJC > Remote	External or Internal	Internal
Input setting > RJC > Remote > Volt (uV)	-20000 to 20000 μ V	0 μ V

<#3 DI/DO/SW Registration>

Parameter	Selectable Range or Selections	Initial Value
Contact input > Module	CTRL1-DI, CTRL1-DO, INT-SW1, INT-SW2, INT-SW3	CTRL1-DI
Contact input > DI001 to 006	None, AllControlStop,	None
Contact input > DO001 to 006	AllControlStart, ControlStart/Stop (1 or 2), Remote/Local (1 or 2), Auto/Man (1 or 2), Cascade (1-2), Auto1-2,	
Contact input > SE001 to 018	Man1-2, SPNumber0 to 3 bit, PVSwitching1 or 2, MemoryStart/Stop, Trigger, AlarmAck, TimeAdjust, MathStart/Stop, MathReset, ManualSample, Panel1Load to Panel3Load, Message1 to 8, Snapshot	

<#4 AUX (Alarm mode...)>

Parameter	Selectable Range or Selections	Initial Value
AUX > Loop number	1 or 2	1
AUX > Remote setting	Off or Remote	Off
AUX > Alarm mode	ALWAYS, STOP, or STOP/MAN	ALWAYS
AUX > SP No. selection source 1 or 2	On/Off	1: On, 2: Off
AUX > PV/SP math	On/Off	Off
AUX > CLOG error	Error, Skip	Error

<#5 Output processing>

Parameter	Selectable Range or Selections	Initial Value
Output processing > Loop number	1 or 2	1
Output processing > Control output	Relay, Voltage-pulse, Current-output, or On/Off-control	Current-output
Output processing > Cycle time	1 s to 1000 s	30 s
Output processing > Analog-output type	4-20 mA, 0-20 mA, 20-4 mA, or 20-0 mA	4-20 mA

<#6 Relay>

Parameter	Selectable Range or Selections	Initial Value
Relay > FAIL	On/Off	Off
Relay > Self diagnosis	On/Off	Off
Relay > DO001 to 006	De_energize/Hold, De_energize/Nonhold, Energize/Hold, or Energize/Nonhold	Energize/Nonhold

List of Parameters

<#7 Tuning setting>

Parameter	Selectable Range or Selections	Initial Value
Tuning setting > Loop number	1 or 2	1
Tuning setting > 01 to 21	On/Off	01-12: On, 13-21: Off
Tuning setting > 01 to 21 > Item ID	SP, A1, A2, A3, A4, P, I, D, OH, OL, MR, PO, H, DR , BS1, FL1, BS2, FL2, RT, RBS, RFL, or W01 to W12	01: SP, 02: A1, 03: A2, 04: A3, 05: A4, 06: P, 07: I, 08: D, 09: OH, 10: OL, 11: MR, 12: PO, 13 to 21: –
Tuning setting > 01 to 21 > Item name	Up to 6 alphanumeric characters	01-12: Same as Item ID 13-21: –

<#8 External loop setting>

Parameter	Value or Selections	Initial Value
#1 Basic setting		
Loop number	Ext1 to Ext4	Ext1
Comm. Off/On	On/Off	Off
Modbus address	1 to 247	1
Connecting model	UT320, UT321, UT350, UT351, UT420, UT450, UT520, UT550, UT750, or Others	UT320
Loop select	First or Second	First
Tag	Up to 8 alphanumeric characters	EXT-01
Tag comment	Up to 8 alphanumeric characters	–
Auto reading	Execute	Execute
PV > Decimals	0 to 4	0
PV > Unit	Up to 6 alphanumeric characters	–
SP > Decimals	0 to 4	0
SP > Unit	Up to 6 alphanumeric characters	–
OUT > Decimals	0 to 4	0
OUT > Unit	Up to 6 alphanumeric characters	%
Control span lower	–30000 to 30000, span width: 30000	0
Control span upper	–30000 to 30000, span width: 30000	10
Control mode	SingleLoopControl, CascadePrimaryLoop, CascadeSecondaryLoop, CascadeControl, ControlBackup, PVSwitching, PVAutoSelector, PVHoldFunction, DualLoopControl, Temperature-Humidity, Cascade-2Uni, PVSwitching-2Uni, PVAutoSelector-2Uni, or CustomComputation	SingleLoopControl
Control output	Relay, Voltage-pulse, Current-output, or On/Off-control	Relay
Alarm	Off, PH-H-E (PV high-limit alarm (energize)), PV-L-E (PV low-limit alarm (energize)), Dev-H-E (Deviation high-limit alarm (energize)), Dev-L-E (Deviation low-limit alarm (energize)), Dev-H-D (Deviation high-limit alarm (deenergize)), Dev-L-D (Deviation low-limit alarm (deenergize)), Dev-HL-E (Deviation high & low limit alarm (energize)), D-W-HL-E (Deviation within high & low limits alarm (energize)), PV-H-D (PV high-limit alarm (deenergize)), PV-L-D (PV low-limit alarm (deenergize)), PV-H-ES (PV high-limit alarm (energize/hold)), PV-L-ES (PV low-limit alarm (energize/hold)), Dev-H-ES (Deviation high-limit alarm (energize/hold)), Dev-L-ES (Deviation low-limit alarm (energize/hold)), Dev-H-DS (Deviation high-limit alarm (deenergize/hold)), Dev-L-DS (Deviation low-limit alarm (deenergize/hold)), Dev-HL-ES (Deviation high & low limit alarm (energize/hold)), D-W-HL-ES (Deviation within high & low limits alarm (energize/hold)), PV-H-DS (PV high-limit alarm (deenergize/hold)), PV-L-DS (PV low-limit alarm (deenergize/hold)), TimeUp1 (Timer, upward detection, hours & minutes), TimeDown1 (Timer, downward detection, hours & minutes), TimeUp2 (Timer, upward detection, minutes & seconds), TimeDown2 (Timer, downward detection, minutes & seconds), Sensor (Sensor grounding alarm), Prog-Diag (Self diagnosis output), FAIL (FAIL output),	Off

Parameter	Value or Selections	Initial Value
	SP-H (SP high-limit), SP-L (SP low-limit), Out-H (Output high-limit), Out-L (Output low-limit), Burnout1 (Heater burnout alarm 1), or Burnout2 (Heater burnout alarm 2),	
#2 Parameter address setting		
Loop number	Ext1 to Ext4	Ext1
PV: Input	30001 to 39999, 300001 to 365535, 40001 to 49999, or 400001 to 465535	40003
SP : Setting	30001 to 39999, 300001 to 365535, 40001 to 49999, or 400001 to 465535	40004
OUT: Output	30001 to 39999, 300001 to 365535, 40001 to 49999, or 400001 to 465535	40005
Control mode	30001 to 39999, 300001 to 365535, 40001 to 49999, or 400001 to 465535	40008
Remote/Local	30001 to 39999, 300001 to 365535, 40001 to 49999, or 400001 to 465535	40008
Operation STOP/RUN	30001 to 39999, 300001 to 365535, 40001 to 49999, or 400001 to 465535	40205
Alarm status	30001 to 39999, 300001 to 365535, 40001 to 49999, or 400001 to 465535	40011
SP number	30001 to 39999, 300001 to 365535, 40001 to 49999, or 400001 to 465535	40010
PID number	30001 to 39999, 300001 to 365535, 40001 to 49999, or 400001 to 465535	40009
Auto reading	30001 to 39999, 300001 to 365535, 40001 to 49999, or 400001 to 465535	40008
#3 Tuning setting		
Tuning setting > Loop number	Ext1 to Ext4	Ext1
Tuning setting > 01 to 21	On/Off	Off
Tuning setting > Item ID	SP, A1, A2, A3, A4, P, I, D, OH, OL, MR, H, DR, DB, PO, or ETC	ETC
Tuning setting > Item name	Up to 6 alphanumeric characters	ETC
Tuning setting > Register address	30001 to 39999, 300001 to 365535, 40001 to 49999, 400001 to 465535	40001
Tuning setting > Decimal point	0 to 4	0
Tuning setting > Range lower	-30000 to 30000, span width: 30000	0
Tuning setting > Range upper	-30000 to 30000, span width: 30000	10

Setting mode (Control)

#1 Control input range

Parameter	Selectable Range or Selections	Initial Value
Input range > Loop number	1 or 2	1
Input range > Input type	PV1, PV2, RemoteSP, or PVrange	PV1
Input range > Mode	TC, RTD, Scale, or 1-5V	TC
Input range > Type	DCV, TC, or RTD	TC
Input range > Range	TC: R/S/B/K/E/J/T/N//W/L/U/PLATI/PR/WRe RTD: PT/JPT DCV: 20mV, 60mV, 200mV, 2V, 6V, 20V, or 50V	K
Input range > Span lower-limit	Within the range of Range	-200.0
Input range > Span upper-limit	Within the range of Range	1370.0
Input range > PV range	-30000 to 30000	Lower: 0.0, Upper: 2000.0
Input range > PV switching Lower limit	-30000 to 30000	0.0
Input range > PV switching Upper limit	-30000 to 30000	2000.0
Input range > Scale	-30000 to 30000	Lower: 0.00, Upper: 200.00
Input range > Unit	Up to 6 alphanumeric characters	-
Input range > Square root	On/Off	Off
Input range > Low-cut	0.0% to 5.0%	1.0%
Input range > Bias	On/Off	Off
	Selectable range when On: EUS (-100.0% to 100.0%) of the measurement span	0.0%
Input range > Filter	On/Off	Off
	1 s to 120 s	1 s
Input range > Ratio	On/Off	Off
	Selectable range when On: 0.001 to 9.999	1.000

List of Parameters

#2 Control alarm

Parameter	Selectable Range or Selections	Initial Value
Alarm > Loop number	1 or 2	1
Alarm > 1 to 4	On/Off	Off
Alarm > Type	PV-H (PV high-limit), PV-L (PV low-limit), Dev-H (deviation high-limit), Dev-L (deviation low-limit), Dev-H&L (deviation high & low limit), D-W-H&L (deviation within high & low limits), SP-H (SP high-limit), SP-L (SP low-limit), Out-H (Output high-limit), or Out-L (Output low-limit)	PV-High
Alarm > Standby	On/Off	Off
Alarm > Relay output	On/Off	Off
Alarm > Number	DO001 to DO006 or SW001 to SW018	DO001
Alarm > SP number	1 to 8	1
Alarm > Alarm value1 to 4	PV high/low limits: EU (0 to 100%) of measurement span, SP high/low limits: EU (0 to 100%) of measurement span, Deviation high/low limits: EUS (-100 to 100%) of measurement span, Deviation high & low limit and deviation within high & low limits: EUS (0 to 100%) of measurement span, or Output high/low limit: -5.0 to 105.0%	1370.0

#3 Operation-related parameter/zone PID

Parameter	Selectable Range or Selections	Initial Value
Operation related/zone PID > Loop number	1 or 2	1
Operation related/zone PID > Suppressing function	Off or Overshoot	Off
Operation related/zone PID > Ramp-rate time unit	Hour, Minute, or Second	Hour
Operation related/zone PID > SP ramp-down-rate	On/Off Selectable range when On: 1digit to EUS (100.0%) of the measurement span	Off 1570.0
Operation related/zone PID > SP ramp-up-rate	On/Off Selectable range when On: 1digit to EUS (100.0%) of the measurement span	Off 1570.0
Operation related/zone PID > Tag	Up to 8 alphanumeric characters	INT-01
Operation related/zone PID > Tag comment	Up to 8 alphanumeric characters	-
Operation related/zone PID > Reference point	EU (0.0 to 100.0%) of the measurement span	1370.0
Operation related/zone PID > Switching hysteresis	EU (0.0 to 100.0%) of the measurement span	7.8
Operation related/zone PID > Reference deviation	On/Off Selectable range when On: 1digit to EUS (100.0%) of the measurement span	Off 7.8

#4 PID parameters

Parameter	Selectable Range or Selections	Initial Value
PID parameters > Loop number	1 or 2	1
PID parameters > PID Number	1 to 8	1
PID parameters > Target setpoint	EU (0% to 100%) of the measurement span	-200.0
PID parameters > Proportional band(P)	0.1% to 999.9%	5.0%
PID parameters > Integral time(I)	0 s to 6000 s	240 s
PID parameters > Derivative time(D)	0 s to 6000 s	60 s
PID parameters > Output lower limit	-5.0% to 105.0%	0.0%
PID parameters > Output upper limit	-5.0% to 105.0%	100.0%
PID parameters > Shutdown	On/Off	Off
PID parameters > Manual reset	-5.0% to 105.0%	50.0%
PID parameters > Relay hysteresis > Value	EUS (0.0 to 100.0%) of the measurement span	7.8
PID parameters > Relay hysteresis > Position	Mid, High, or Low	Mid
PID parameters > Reverse/Direct	Reverse or Direct	Reverse
PID parameters > Preset output	-5.0% to 105.0%	0.0%

#5 Control group setting

Parameter	Selectable Range or Selections	Initial Value
Control group > Group number	1 to 4	1
Control group > Group name	Up to 16 alphanumeric characters	CONTROL GROUP1
Control group > 1 to 4	On/Off	1/2: On, 3/4: Off
Control group > 1 to 4 > Kind	Int-Loop, Ext-Loop, or Meas-CH	Int-Loop
Control group > 1 to 4 > Number	Int-Loop: 01 or 02 Ext-Loop: 01 to 04 Meas-CH: 01 to 06	1: 01, 2: 02

#6 Ten-segment linearizer I/O

Parameter	Selectable Range or Selections	Initial Value
Ten-segment linearizer I/O > Loop number	1 or 2	1
Ten-segment linearizer I/O > Input type	PV1 or PV2	PV1
Ten-segment linearizer I/O > Mode	Off, Biasing, or Approximation	Off
Ten-segment linearizer I/O > Input 1 to 11	Linearizer bias: EU (-5.0% to 105.0%) of the measurement span Linearizer approximation: EU (-5.0% to 105.0%) of the measurement span	1: -200.0, 2: 1370.0, 3 to 11: -200.0
Ten-segment linearizer I/O > Output 1 to 11	Linearizer bias: EUS (-100.0% to 100.0%) of the measurement span Linearizer approximation: EU (-5.0% to 105.0%) of the measurement span	0.0

#7 Program control related (only when program control is ON)**<#1 Program parameter setting>**

Parameter	Selectable Range or Selections	Initial Value
#1 Pattern initial setting		
Program initial setting > Pattern number	1 to 4 (/PG1), 1 to 30 (/PG2)	1
Program initial setting > Segments	0 to 99	0
Program initial setting > Segment setting method	Time, Ramp	Time
Program initial setting > Pattern name	Up to 16 alphanumeric characters	Pattern 1
#2 Wait action setting		
Wait action setting > Wait zone 1 to 5 > Loop 1, 2 > H, L	On/Off EUS (100.0%) of the measurement span	Off 1 digit
Wait action setting > Wait time	00:00:00 to 99:59:59	00:00:00
#3 Pattern start setting		
Pattern start setting > Start target setpoint > Loop 1, 2	EU (0% to 100%) of the measurement span	-200.0
Pattern start setting > Start code	StartTargetSP, RampPV1 to RampPV6, TimePV,	StartTargetSP
#4 Program pattern setting		
Program pattern setting > Segment number	1 to specified number of segments	1
Program pattern setting > Ramp/Soak select	Ramp, Soak	Ramp
Program pattern setting > Target setpoint > Loop 1, 2	EU (0% to 100%) of the measurement span	-200.0
Program pattern setting > Segment time ¹	00:00:00 to 99:59:59	00:00:01
Program pattern setting > Ramp-rate time unit ²	Hour, Minute	Hour
Program pattern setting > Ramp ²	1 digit to EUS (100.0%) of the measurement span	1 digit
Program pattern setting > Segment PID group No.	1 to specified PID number	1
Program pattern setting > Segment shift action	Continue, HoldShift, LocalShift, ResetShift	Continue
Program pattern setting > Wait action	Off, Shift, Within	Off
Program pattern setting > Wait zone number	1 to 5	1

List of Parameters

Parameter	Selectable Range or Selections	Initial Value
#5 Event setting		
Event setting > Segment number	1 to specified number of segments	1
Event setting > Event kind	PVEvent, TimeEvent	TimeEvent
Event setting > Event No.	1-8, 9-16	1-8
Event setting > TimeEvent 1 to 16	On1, On2, On3, Off	Off
Event setting > TimeEvent 1 to 16 > On-time, Off-time	00:00:00 to 99:59:59	00:00:00
Event setting > PVEvent 1 to 16 > Loop	Off, 1 to 6	Off
Event setting > PVEvent 1 to 16 > Loop > Type	PV-High, PV-Low, Deviation-High, Deviation-Low, Deviation-H&L, Dev-within-H6L, SP-High, SP-Low, Output-High, Output-Low	PV-High
Event setting > PVEvent 1 to 16 > Loop > Value	PV: EU (0% to 100%) of the measurement span Deviation: EUS (0% to 100%) of the measurement span SP: EU (0% to 100%) of the measurement span Output: -5.0 % to 105.0 %	1370.0 1570.0 1370.0 105.0 %
#6 Event output setting		
Event output > Event kind	PVEvent, TimeEvent	TimeEvent
Event output > Relay Output EV1 to 16	On, Off	Off
Event output > On EV1 to 16 > Number	DO001 to DO006, SW001 to SW018	DO001
Program pattern end signal > Relay Output	On, Off	Off
Program pattern end signal > On > Number	DO001 to DO006, SW001 to SW018	DO001
#7 Hysteresis (PV event)		
Hysteresis (PV event) > PV event > Hysteresis 1 to 16	0.0% to 10.0	0.5%
#8 Repeat action setting		
Repeat action setting > Repeat action	Off, On, Repeat	Off
Repeat action setting > On > Repeat frequency	1 to 999	1
Repeat action setting > Repeat action > Repeat start segment	1 to specified number of segments	1
Repeat action setting > Repeat action > Repeat end segment	1 to specified number of segments	1

¹ When [Time] is specified for the segment setting method.

² When [Ramp] is specified for the segment setting method.

<#2 Event output setting>

Parameter	Selectable Range or Selections	Initial Value
Event output > Event kind	PVEvent, TimeEvent	TimeEvent
Event output > Relay (EV1 to 16)	On/Off	Off
Event output > On (EV1 to 16) > No.	DO001 to DO006	DO001
Program end signal	On/Off	Off
Program end signal > On	DO001 to DO006	DO001

<#2 AUX (Auto message, Display position)>

Parameter	Selectable Range or Selections	Initial Value
AUX (Auto message, Display position) > Auto message for program Run/Reset On/Off	On, Off	On
AUX (Auto message, Display position) > Program display position > Position > Loop 1 to 6	1 or 2	Loop 1, 2: 1, 2
AUX (Auto message, Display position) > Auto change to program run display	On, Off	Off

<#3 AUX (Event group)>

Parameter	Selectable Range or Selections	Initial Value
AUX (Event group) > Pattern number	1 and 2	1
AUX (Event group) > 1 to 5	On, Off	On
AUX (Event group) > On 1 to 5 > Kind	PVEvent, TimeEvent	Time Event
AUX (Event group) > Number	01 to 05	1 to 5: 01 to 05

#8 Detailed settings (#7 when the program control function is OFF)**<#1 Control function>**

Parameter	Selectable Range or Selections	Initial Value
Control function > Loop number	1 or 2	1
Control function > SP Tracking	Off/On	On
Control function > PV tracking	On/Off	Off
Control function > Target setpoint limiter > Lower	EU (0.0% to 100.0%) of the measurement span	-200.0
Control function > Target setpoint limiter > Upper	EU (0.0% to 100.0%) of the measurement span	1370.0
Control function > Output velocity limiter	On/Off	Off
	Enter the value for On: 0.1%/s to 100.0%/s	100.0%/s
Control function > Anti-reset windup	Auto or Manual	Auto
	Enter the value for Manual: 50.0% to 200.0%	100.0%

<#2 Hysteresis (Alarm)>

Parameter	Selectable Range or Selections	Initial Value
Hysteresis (Alarm) > Alarm > Loop number	1 or 2	1
Hysteresis (Alarm) > Alarm > Hysteresis1 to 4	EUS (0.0% to 10.0%) of the measurement span	7.8

<#3 DIO monitor and operation setting>

Parameter	Selectable Range or Selections	Initial Value
DIO monitor and operation setting >	01 to 12	01
DIO entry number		
DIO monitor and operation setting > On/Off	On, Off	Off
DIO monitor and operation setting > Kind	DI-1, DO-1, DO-2, DIO-11, DIO12, DO-2P, DIO-12P	DI-1
DIO monitor and operation setting > SW number	SW001 to SW018	SW001
DIO monitor and operation setting > DO number > ON	DO001 to DO006	DO001
DIO monitor and operation setting > DO number > OFF	DO001 to DO006,	DO001
DIO monitor and operation setting > DI number	DI001 to DI006	DI001
DIO monitor and operation setting > Tag	Up to 8 alphanumeric characters	-
DIO monitor and operation setting > Tag comment	Up to 8 alphanumeric characters	-
DIO monitor and operation setting >	Up to 8 alphanumeric characters	-
Operation property >ON > Label		
DIO monitor and operation setting >	Red, green, blue, blue violet, brown, orange, yellow-green, light blue, violet, gray, lime, cyan, dark blue, yellow, light gray, or purple	Red
Operation property >ON > Color		
DIO monitor and operation setting >	Up to 8 alphanumeric characters	-
Operation property >OFF > Label		
DIO monitor and operation setting >	Red, green, blue, blue violet, brown, orange, yellow-green, light blue, violet, gray, lime, cyan, dark blue, yellow, light gray, or purple	Red
Operation property >OFF > Color		

<#4 DI/DO label setting>

Parameter	Selectable Range or Selections	Initial Value
DI/DO label setting > Module	CTRL1-DI, CTRL1-DO	CTRL1-DI
DI/DO label setting > DI001 to DI006 > Label	Up to 16 alphanumeric characters	DI001 to DI006
DI/DO label setting > DO001 to DO006 > Label	Up to 16 alphanumeric characters	DO001 to DO006

List of Parameters

#9 Detailed settings (#8 when the program control function is OFF)

<#1 PV/SP math, Retransmission>

Parameter	Selectable Range or Selections	Initial Value
PV/SP math, Retransmission > Loop number	1 or 2	1
PV/SP math, Retransmission > PV/SP	PV, PV1, pV2, SP (Depending on the control mode)	Value depending on the control mode
PV/SP math, Retransmission > Mode	On/Off	Off
PV/SP math, Retransmission > Calculation expression	Up to 120 alphanumeric characters	Previously determined control input channel No.
PV/SP math, Retransmission > PV range > Lower-limit	-30000 to 30000 (upper-lower ≤ 30000)	Measurement range of calculation expression initial value
PV/SP math, Retransmission > PV range > Upper-limit	-30000 to 30000 (upper-lower ≤ 30000)	Measurement range of calculation expression initial value
PV/SP math, Retransmission > Unit	Up to 6 alphanumeric characters	–
PV/SP math, Retransmission > PV swithing > Lower	-30000 to 30000 (upper-lower ≤ 30000)	Lower limit of PV range
PV/SP math, Retransmission > PV swithing > Upper	-30000 to 30000 (upper-lower ≤ 30000)	Upper limit of PV range
PV/SP math, Retransmission > Math error	Over, Under	Over

<#2 Logic math>

Parameter	Selectable Range or Selections	Initial Value
Logic math > Setting number	1-6, 7-12	1-6
Logic math > Relay	Off, DO001 to DO006, SW001 to SW018	Off
Logic math > Calculation expression	Up to 120 alphanumeric characters	–

<#3 Constant>

Parameter	Selectable Range or Selections	Initial Value
Constant > W01 to W12	-9.9999E+29 to -1.0000E-30, 0, 1.0000E-30 to 9.9999E+29	1

Set mode

#1 Range, Alarm

Parameter	Selectable Range or Selections	Initial Value
First-CH	01 to 06	01
Last-CH	01 to 06	01
Range > Mode	Volt, TC, RTD, Scale, Delta, DI, Sqrt, or Skip	Volt
Range > Range	20 mV, 60 mV, 200 mV, 2 V, 6 V, 20 V, 50 V, R, S, B, K, E, J, T, N, W, L, U, PLATI, PR, Wre, PT, JPT, Level, or Cont	2 V
Range > Span Lower	–	-2.000
Range > Span Upper	–	2.000
Alarm > 1 to 4	On/Off	Off
Alarm > Type	H: High limit, L: Low limit, R: Rate-of-change, T: Delay high, t: Delay low	H
Alarm > Value	–	0.000
Alarm > Relay	On/Off	Off
Alarm > Relay Number	I01 to I06, DO001 to DO006, or SW001 to SE018	I01
Alarm > Detect	On/Off	On

#2 Tag, Moving average, Alarm delay time

Parameter	Selectable Range or Selections	Initial Value
First-CH	01 to 06, 101 to 106, or 201 to 212	01
Last-CH	01 to 06, 101 to 106, or 201 to 212	01
Tag	Up to 16 alphanumeric characters	01
Moving average > Count	Off, 2, 3, 4, 5, 6, 7, 8, 9, 10, 11, 12, 13, 14, 15, or 16	Off
Alarm delay > Time	1 s to 3600 s	10 s

#3 Trend/Save interval, User key

Parameter	Selectable Range or Selections	Initial Value
Trend/Save interval > Time/div	1 min, 2 min, 5 min, 10 min, 20 min, 30 min, 1 h, 2 h, 4 h, or 10 h	1 min
Trend/Save interval > Auto save interval	10 minutes to 31 days	1 h
USER key > Action	None, Trigger, AlarmACK, MathStart/Stop, MathReset, ManualSample, Message1 - Message8, or Snapshot	AlarmACK

#4 Message

Parameter	Selectable Range or Selections	Initial Value
Message > Characters No. 1 to No. 8	Up to 16 alphanumeric characters	–

#5 Display**<#1 Group set, Trip line>**

Parameter	Selectable Range or Selections	Initial Value
Group number	1 to 6	1
Group set > Group name	Up to 16 alphanumeric characters	GROUP 1
Group set > CH set	01 to 06, 101 to 106, or 201 to 212	01-06
Group set > Trip line > No. 1 to No. 4	On/Off	Off
Group set > Trip line > Position	0% to 100%	100%
Group set > Trip line > Color	Red, green, blue, blue violet, brown, orange, yellow-green, light blue, violet, gray, lime, cyan, dark blue, yellow, light gray, or purple	No.1: Red, No.2: Green, No.3: Blue, No.4: Yellow

<#2 Color>

Parameter	Selectable Range or Selections	Initial Value
Color > CH1	Red, green, blue, blue violet, brown, orange, yellow-green, light blue, violet, gray, lime, cyan, dark blue, yellow, light gray, or purple	Red
Color > CH2	Same as above	Green
Color > CH3	Same as above	Blue
Color > CH4	Same as above	Blue-violet
Color > CH5	Same as above	Brown
Color > CH6	Same as above	Orange

<#3 Zone, Graph, Partial>

Parameter	Selectable Range or Selections	Initial Value
First-CH	01 to 06	01
Last-CH	01 to 06	01
Zone > Lower	0% to 95%	0%
Zone > Upper	5% to 100%	100%
Graph > Division	4, 5, 6, 7, 8, 9, 10, 11, 12, or C10	10
Graph > Bar graph	Normal or Center	Normal
Graph > Scale position	Off or 1 to 6	1
Partial	On/Off	Off
Expand	1% to 99%	50%
Boundary	Minimum span value + 1 digit to maximum span value – 1 digit (for channels set to a range other than scale or square root computation) or minimum scale value + 1 digit to maximum scale value – 1 digit (for channels set to scale or square root computation)	–

<#4 View, Direction, LCD>

Parameter	Selectable Range or Selections	Initial Value
View > Direction > Trend	Horizontal, Vertical, or Horizon2	Vertical
View > Direction > Bar graph	Horizontal or Vertical	Vertical
View > Background > Measure	White or Black	White
View > Background > Control	White or Black	Black
View > Trend line	1, 2, or 3 dots	2 dots
View > Trip line	1, 2, or 3 dots	2 dots
View > Grid	Auto, 4 div, 5 div, 6 div, 7 div, 8 div, 9 div, 10 div, 11 div, or 12 div	10 div
View > Scroll	5 s, 10 s, 20 s, 30 s, 1 min	5s

List of Parameters

Parameter	Selectable Range or Selections	Initial Value
View > Scale digit	Normal or Fine	Normal
LCD > Brightness	1 to 8	4
LCD > Backlight saver > On/Off	On/Off	Off
LCD > Backlight saver > Saver time	1 min, 2 min, 5 min, 10 min, 30 min, or 1 h	1 h
LCD > Restore	Key or Key+Alm	Key+Alm

<#5 Control (Color)>

Parameter	Selectable Range or Selections	Initial Value
Select	Internal or External	Internal
CH101	Red, green, blue, blue violet, brown, orange, yellow-green, light blue, violet, gray, lime, cyan, dark blue, yellow, light gray, or purple	Red
CH102	Same as above	Green
CH103	Same as above	Blue
CH104	Same as above	Blue-violet
CH105	Same as above	Brown
CH106	Same as above	Orange

<#6 Control (Zone, Graph, Partial)>

Parameter	Selectable Range or Selections	Initial Value
First-CH	101 to 106 or 201 to 212	101
Last-CH	101 to 106 or 201 to 212	101
Zone Lower	0% to 95%	0%
Zone Upper	5% to 100%	100%
Graph > Division	4, 5, 6, 7, 8, 9, 10, 11, 12, or C10	10
Graph > Bar graph	Normal or Center	Normal
Graph > Scale position	Off or 1 to 10	1
Partial	On/Off	Off
Expand	1% to 99%	50%
Boundary	Minimum span value + 1 digit to maximum span value – 1 digit (for channels set to a range other than scale or square root computation) or minimum scale value + 1 digit to maximum scale value – 1 digit (for channels set to scale or square root computation)	0.1

<#7 Math (Color)>

Parameter	Selectable Range or Selections	Initial Value
CH31	Red, green, blue, blue violet, brown, orange, yellow-green, light blue, violet, gray, lime, cyan, dark blue, yellow, light gray, or purple	Red
CH32	Same as above	Green
CH33	Same as above	Blue
CH34	Same as above	Blue-violet
CH35	Same as above	Brown
CH36	Same as above	Orange
CH37	Same as above	Yellow-green
CH38	Same as above	Light blue
CH39	Same as above	Violet
CH40	Same as above	Gray
CH41	Same as above	Lime
CH42	Same as above	Cyan

<#8 Math (Zone, Graph, Partial)>

Parameter	Selectable Range or Selections	Initial Value
First-CH	31 to 42	31
Last-CH	31 to 42	31
Zone > Lower	0% to 95%	0%
Zone > Upper	5% to 100%	100%
Graph > Division	4, 5, 6, 7, 8, 9, 10, 11, 12, or C10	10
Graph > Bar graph	Normal or Center	Normal
Graph > Scale position	1 to 10 or Off	1
Partial	On/Off	Off
Expand	1% to 99%	50%
Boundary	Minimum span value + 1 digit to maximum span value – 1 digit (for channels set to a range other than scale or square root computation) or minimum scale value + 1 digit to maximum scale value – 1 digit (for channels set to scale or square root computation)	0.00

#6 File, DST

Parameter	Selectable Range or Selections	Initial Value
File > Header	Up to 32 alphanumeric characters	–
File > Directory name	Up to 8 alphanumeric characters	DATA0
File > Save data	Unsave or All	All
Daylight saving time (YY/MM/DD HH) > Summer	Off/On	Off
Daylight saving time (YY/MM/DD HH) > Winter	Off/On	Off

#7 Save/Load, Clear data

Parameter	Selectable Range or Selections	Initial Value
#1 Save settings	–	–
#2 Load settings	–	–
#3 Save data	–	–
#4 Load display data	–	–
#5 Load event data	–	–
#6 File list	–	–
#7 Delete	–	–
#8 Format	–	–
#9 Clear data	–	–

#8 Time

Parameter	Selectable Range or Selections	Initial Value
Time set	–	–

#9 Math set1 (expression, alarm)

Parameter	Selectable Range or Selections	Initial Value
First-CH	31 to 42	31
Last-CH	31 to 42	31
Math range > Math On/Off	On/Off	Off
Math range > Calculation expression	40 characters or less.	01
Math range > Span Lower	–9999999 to 99999999 (decimal point: within 4 digits to the right of the decimal point)	–200.00
Math range > Span Upper	–99999999 to 999999999 (decimal point: within 4 digits to the right of the decimal point)	200.00
Math range > Unit	Up to 6 alphanumeric characters	–
Alarm > 1 to 4	On/Off	Off
Alarm > Type	H, L, T, or t	H
Alarm > Value	Value within the measurement span	0.00
Alarm > Relay On/Off	On/Off	Off
Alarm > Relay Number	I01 to I06 or DO001 to DO006	I01

List of Parameters

#10 Math set2 (constant)

Parameter	Selectable Range or Selections	Initial Value
Constant > K01 to K12	-9.9999E+29 to -1.0000E-30, 0, 1.0000E-30 to 9.9999E+29	1

#11 Math set3 (tag, TLOG, rolling average, alarm delay)

Parameter	Selectable Range or Selections	Initial Value
First-CH	31 to 42	31
Last-CH	31 to 42	31
Tag > Tag	Up to 16 alphanumeric characters	31
TLOG > Timer No.	1, 2, or 3	1
TLOG > Sum scale	Off, /s, /min, or /h	Off
Rolling average	On/Off	Off
Rolling average > Interval	1 s, 2 s, 3 s, 4 s, 5 s, 6 s, 10 s, 12s, 15s, 20s, 30s, 1 min, 2 min, 3 min, 4 min, 5 min, 6 min, 10 min, 12 min, 15 min, 20 min, 30 min, or 1 h	10 s
Rolling average > Number of samples	1 to 64	1
Alarm delay time	1 s to 3600 s	10 s

#12 Batch set

Parameter	Selectable Range or Selections	Initial Value
Application name	Up to 16 alphanumeric characters	-
Supervisor name	Up to 16 alphanumeric characters	-
Manager name	Up to 16 alphanumeric characters	-
Batch number	Up to 16 alphanumeric characters	-
Lot number	Up to 4 alphanumeric characters	-
Auto increment	On/Off	On
Disp information	Brтч, Time	Batch



YOKOGAWA ELECTRIC CORPORATION

Headquarters

2-9-32, Nakacho, Musashino-shi, Tokyo, 180-8750 JAPAN

Sales Headquarters

2-9-32, Nakacho, Musashino-shi, Tokyo, 180-8750 JAPAN
Phone : 81-422-52-6194

Branch Sales Offices

Nagoya, Osaka, Hiroshima, Fukuoka, Sapporo, Sendai, Ichihara, Toyoda, Kanazawa, Takamatsu, Okayama, and Kitakyusyu.

Overseas Representative Offices / Service Centers

Beijing, Shanghai (The People's Republic of China), Jakarta (Indonesia), Kuala Lumpur (Malaysia), Bangkok (Thailand)

YOKOGAWA CORPORATION OF AMERICA

Headquarters

2 Dart Road, Newnan, Ga. 30265-1094, U.S.A.
Phone : 1-770-253-7000
Fax : 1-770-251-0029

Branch Sales Offices / Detroit, Chicago, Los Angeles, Massachusetts, New Jersey, North Carolina, Oklahoma, Pennsylvania, Texas

YOKOGAWA EUROPE B. V.

Headquarters

Databankweg 20 Amersfoort 3821 AL, THE NETHERLANDS
Phone : 31-334-64-1611 Fax : 31-334-64-1610

Branch Sales Offices / Wien (Austria), Zaventem (Belgium), Ratingen (Germany), Madrid (Spain), Runcorn (United Kingdom), Milano (Italy), Velizy Villacoublay (France), Johannesburg (Republic of South Africa)

YOKOGAWA AMERICA DO SUL S.A.

Praca Acapulco, 31 - Santo Amaro. Sao Paulo/SP - BRAZIL
Phone : 55-11-5681-2400 Fax : 55-11-5681-1274

YOKOGAWA ELECTRIC ASIA PTE. LTD.

Head Office

5 Bedok South Road, 469270 SINGAPORE
Phone : 65-241-9933 Fax : 65-444-6252

YOKOGAWA ELECTRIC KOREA CO., LTD.

Head Office

420-5, Chongchon - 2dong, Pupyong - ku Incheon, 403-032 KOREA
Phone : 82-32-510-3107 Fax : 82-32-529-6304

YOKOGAWA AUSTRALIA PTY. LTD.

Head Office (Sydney)

Centrecourt D1, 25-27 Paul Street North, North Ryde, N.S.W.2113, AUSTRALIA
Phone : 61-2-9805-0699 Fax : 61-2-9888-1844

YOKOGAWA BLUE STAR LTD.

Head Office

40 / 4 Lavelle Road, Bangalore 560 001, INDIA
Phone : 91-80-2271513 Fax : 91-80-2274270

Oct. '00